



This is a digital copy of a book that was preserved for generations on library shelves before it was carefully scanned by Google as part of a project to make the world's books discoverable online.

It has survived long enough for the copyright to expire and the book to enter the public domain. A public domain book is one that was never subject to copyright or whose legal copyright term has expired. Whether a book is in the public domain may vary country to country. Public domain books are our gateways to the past, representing a wealth of history, culture and knowledge that's often difficult to discover.

Marks, notations and other marginalia present in the original volume will appear in this file - a reminder of this book's long journey from the publisher to a library and finally to you.

Usage guidelines

Google is proud to partner with libraries to digitize public domain materials and make them widely accessible. Public domain books belong to the public and we are merely their custodians. Nevertheless, this work is expensive, so in order to keep providing this resource, we have taken steps to prevent abuse by commercial parties, including placing technical restrictions on automated querying.

We also ask that you:

- + *Make non-commercial use of the files* We designed Google Book Search for use by individuals, and we request that you use these files for personal, non-commercial purposes.
- + *Refrain from automated querying* Do not send automated queries of any sort to Google's system: If you are conducting research on machine translation, optical character recognition or other areas where access to a large amount of text is helpful, please contact us. We encourage the use of public domain materials for these purposes and may be able to help.
- + *Maintain attribution* The Google "watermark" you see on each file is essential for informing people about this project and helping them find additional materials through Google Book Search. Please do not remove it.
- + *Keep it legal* Whatever your use, remember that you are responsible for ensuring that what you are doing is legal. Do not assume that just because we believe a book is in the public domain for users in the United States, that the work is also in the public domain for users in other countries. Whether a book is still in copyright varies from country to country, and we can't offer guidance on whether any specific use of any specific book is allowed. Please do not assume that a book's appearance in Google Book Search means it can be used in any manner anywhere in the world. Copyright infringement liability can be quite severe.

About Google Book Search

Google's mission is to organize the world's information and to make it universally accessible and useful. Google Book Search helps readers discover the world's books while helping authors and publishers reach new audiences. You can search through the full text of this book on the web at <http://books.google.com/>

... ON THE ...
ADJUSTMENT AND
TESTING
... OF ...
TELESCOPIC
OBJECTIVES.

— — —
SECOND EDITION.
— — —

T. COOKE & SONS,

Buckingham Works, York.

York:

PRINTED BY DELITTLE & SONS, 6, RAILWAY STREET.

1896.

Astly 508.96



Harvard College Library

BOUGHT WITH INCOME

FROM THE BEQUEST OF

HENRY LILLIE PIERCE,
OF BOSTON,

Under a vote of the President and Fellows,
October 24, 1898.

16 June, 1899.

SCIENCE CENTER LIBRARY

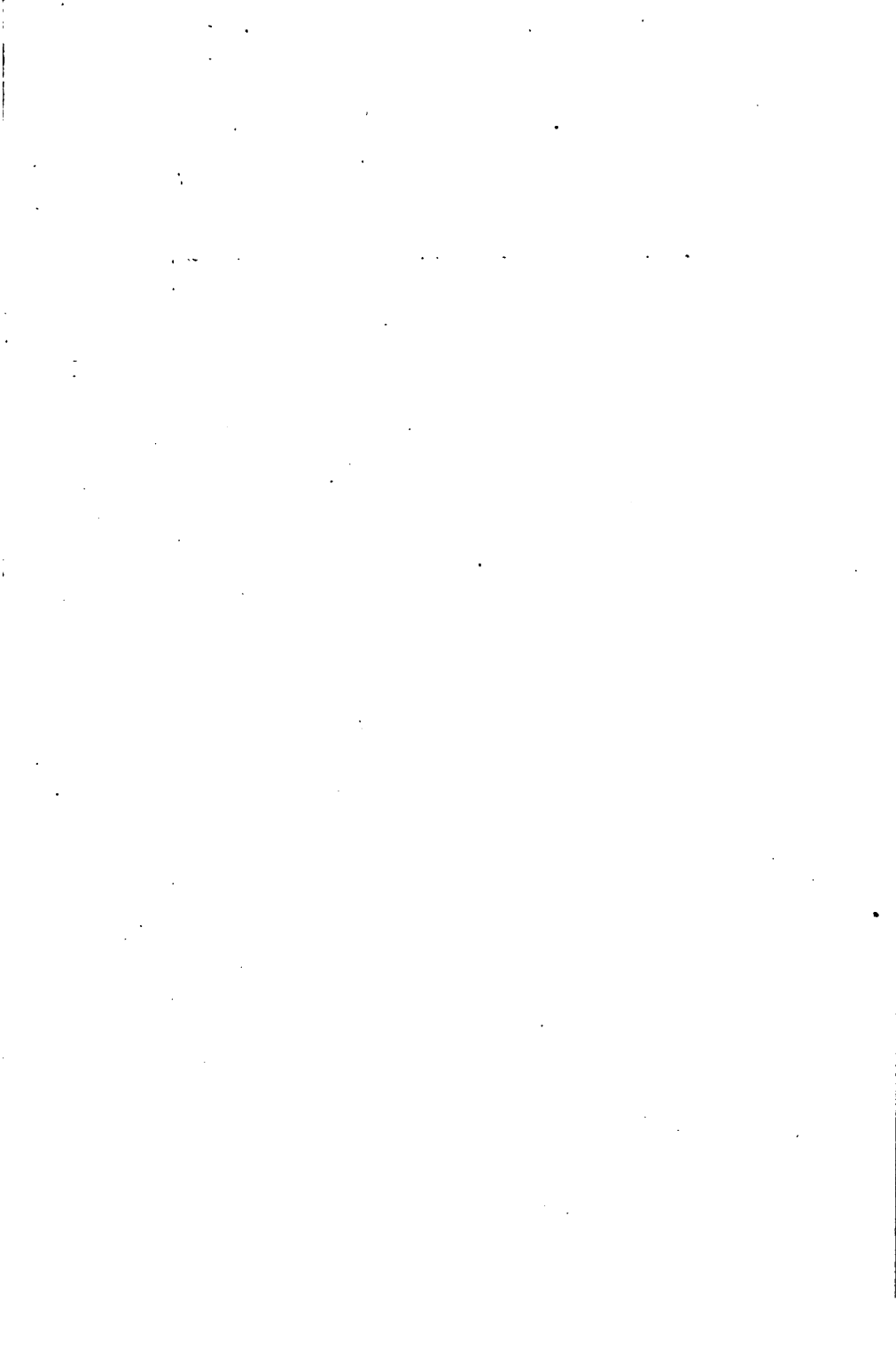



ON THE ADJUSTMENT AND
TESTING

... OF ...

TELESCOPIC
OBJECTIVES.

SECOND EDITION.

T. COOKE & SONS,

BUCKINGHAM WORKS, YORK.

York:

PRINTED BY DELITTLE & SONS, 6, RAILWAY STREET.

—
1896.

Astr 508.96

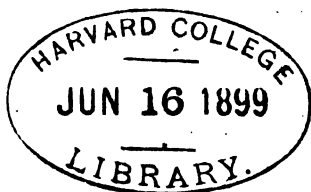

Pierce fund

PREFACE TO SECOND EDITION.

ENCOURAGED by the favourable reception accorded to our little book, "*On the Adjustment and Testing of Telescopic Objectives*," in the printed reviews, and in many private letters received from astronomers, and as attested by the fact that it has been deemed worthy to be translated into German by Dr. Rudolph Straubel, of Jena, and into Italian by Prof. Tacchini, we have thought ourselves justified in preparing a second and enlarged edition.

Since the date of publishing the first edition, in the summer of 1891, Mr. H. Dennis Taylor, our optical manager, has entered into many calculations and experiments on our behalf, with a view to the further improvement of the so-called achromatic telescope, with the result that we were able, in the spring of 1894, to offer to astronomers an entirely new objective, practically free from secondary colour aberrations, and capable of being used for celestial photography without any special adjustment. Seeing that our new Triple Photo-Visual Objective is rapidly supplanting the old double form, we have considered it necessary to insert a supplementary chapter upon its adjustment, while retaining all instructions relating to ordinary double objectives, many of which will, doubtless, be in use for a considerable time.

By the kind permission of the Council of the Royal Astronomical Society, we are enabled to reprint, in the form of an appendix, Mr. Dennis Taylor's paper on "*The Secondary Colour Aberrations of the Refracting Telescope in relation to Vision*," in which the great detriment suffered by large refractors of the ordinary type, by reason of their imperfect colour corrections, is fully dealt with; and also his paper entitled "*A Description of a Perfectly Achromatic Refractor*," in which our new Photo-Visual Objective is described. The general text of the book has been enlarged and modified in order to embody the latest information on the subject.



FIG 10



FIG 11



FIG 17



FIG 18



a



a'



b



b'



c



c'



d



d'

FIG 12



FIG 19



FIG 19a



FIG 13



FIG 14



FIG 20



FIG 20a



FIG 15



FIG 15a



FIG 21



FIG 21a



FIG 22



FIG 22a



FIG 16



FIG 16a



FIG 23



a



FIG 24



c

INDEX TO FRONTISPIECE.

- Fig. 10a.*—Eccentric appearance of interference rings, due to the objective being out of adjustment. See page 14.
- c.* The focussed image of a star, when the maladjustment is about as much as in the last case.
- b.* The focussed image, as visible when the objective is moderately out of square.
- Fig. 11.*—A section of the cone of rays taken closer to the focus, exhibiting a more moderate degree of maladjustment. See page 15.
- Fig. 12.*—*a, b, c, d* and *d'* are out of focus sections, as will be seen when the objective is correctly "squared on," and quite irrespective of other faults. See pages 16 and 17.
- a', b' and d''* are appearances of the focussed image corresponding respectively to *a, b and d*.
- d, d' and d''* are also examples of astigmatism. See page 26.
- Fig. 13.*—A section taken a very little way within focus, under a high power, exhibiting the fault of astigmatism. See page 28.
- Fig. 14.*—The corresponding appearance to *Fig. 13*, as shown by a section taken at the same distance *beyond* focus. See page 28.
- Fig. 15.*—Section within focus, showing result of positive spherical aberration. See page 30.
- Fig. 15a.*—The corresponding section, taken at the same distance beyond focus. See page 30.
- Fig. 16.*—A section taken closer to focus under a high power, exhibiting a slight residual spherical aberration; the central rings rather weak. See page 30.
- Fig. 16a.*—The corresponding appearance at the same distance beyond focus; the central rings relatively strong. See page 30.
- Fig. 17.*—The spurious disc or image of a star yielded by a perfect objective, and viewed under a very high magnifying power. See page 34.
- Fig. 18.*—The spurious disc sometimes yielded by a large objective when resting upon three points, without intermediate supports being supplied to counteract the flexure due to the weight of the lenses. See page 44.
- Figs. 19 and 19a.*—An example of marked zonal aberration, being sections of the cone of rays taken inside and outside of focus respectively. See page 32.
- Figs. 20 and 20a.*—Another example of zonal aberration. See page 32.
- Figs. 21 and 21a.*—Example of the general figure of an objective being tolerably good, but there is a region in the centre having a focus somewhat beyond the main focus. See page 32.

Figs. 22 and 22a.—Two sections of the cone of rays yielded by a perfect objective, taken very near to and on opposite sides of focus, and viewed under a high power. See pages 30 and 33.

Fig. 23.—A section of the cone of rays yielded by a perfect objective, taken at about $\frac{1}{4}$ -inch on either side of focus, and viewed under a moderately high magnifying power. See page 33.

Fig. 24a.—Example of violent mechanical strain, due to imperfect mounting or bad annealing. See page 41.

Fig. 24.—Ditto.

Fig. 24b.—Example of the effects due to the presence of veins in the material of the objective.



TABLE OF CONTENTS.

	PAGE
SQUARING ON	8
ACHROMATISM	19
FALSE CENTERING	24
ASTIGMATISM	26
SPHERICAL ABERRATION	29
ZONAL ABERRATION	31
PERFECT FIGURE	33
THE STAR IMAGE	34
MECHANICAL STRAINS	40
THE RELATION BETWEEN THE FORM OF THE CURVES AND THE OPTICAL EFFECT OF FLEXURE	45
TERRESTRIAL TELESCOPES	48
REFLECTORS	48
THE KNIFE-EDGE METHOD OF TESTING	49
THE COOKE PHOTO-VISUAL OBJECTIVE	57
GENERAL TREATMENT OF OBJECTIVES	60
THE SECONDARY COLOUR ABERRATIONS OF THE REFRACTING TELESCOPE IN RELATION TO VISION	67
DESCRIPTION OF A PERFECTLY ACHROMATIC REFRACTOR	87

The Adjustment and Testing of Telescopic Objectives.

IN these days all astronomers, whether amateur or otherwise, must be provided with some form of telescope if their study is to be in any degree satisfactory and fruitful of results, and moreover, such instruments must come up to a certain standard of excellence and be properly adjusted, before they can be expected to yield the best definition attainable by the particular size in question.

The old established reflecting telescope still remains the favourite with many observers, chiefly by reason of its smaller cost and its perfect achromatism, but there is no doubt that the refracting telescope is generally recognised as the most convenient and generally reliable form of telescope, principally because it will perform well on nights when the reflector is useless owing to the deposit of dew and the distracting effect of insidious air currents within the tube.

But there are refractors and refractors, varying greatly in their intrinsic qualities. Among the large number of objectives which we have had submitted to us for our opinion, we have found the greater proportion very indifferent in their performance. Sometimes we have found second rate objectives enjoying a reputation for high quality in some quarters, chiefly for the reason, as it seems to us, that there is a lack of published information of an authentic and complete character enabling the amateur to make a sufficiently accurate estimate of the quality of an objective for himself.

On the other hand, we have had forced upon our attention the fact that occasionally objectives of *first rate quality* are nevertheless looked upon as defective, because those who use them have been insufficiently informed as to the necessary adjustments, and therefore their objectives are put to a more or less serious disadvantage. Such facts as these, among many others, as well as the wish to minister to the very natural desire on the part of astronomers to understand the instruments with which they work and upon whose good performance they depend, prompt us to publish the following remarks for the purpose of enabling them to gain the very utmost advantage from the use of their instruments.

SQUARING ON.

In the first place it may be pointed out that portable and pocket telescopes of under three inches aperture and used for terrestrial purposes are adjusted by their makers before being sent out, and moreover are not usually supplied with apparatus for adjustment, as the comparatively low magnifying powers used on such telescopes render a perfect adjustment of the objective unnecessary. Of course, good objectives for astronomical purposes, if supplied with tube and mounting, are also sent out in good adjustment, as far as possible; nevertheless, after they have been in use for some time, or the objective has been taken out for cleaning, etc., or still more, if they have changed hands and undergone vicissitudes of some sort or another, there will arise need for more or less readjustment of the objective with respect to its tube, or "squaring on" as the operation is called.

Sometimes the maker has to supply a large telescope to be put up at some distant place (in Australia, for instance), in which case it may be impracticable to send some well qualified person to see to the final adjustment of the objective in its tube; or again, an objective may be supplied by itself, in which case its adjustment by the maker is not demanded, but is undertaken by its owner or a friend. It is therefore very important that anyone who uses an astronomical telescope of any considerable aperture should be able to perform the operation of "squaring on" the objective to a nicety, for unless this is done the telescope will not perform its best with the highest magnifying powers, especially in the way of separating difficult double stars.

Technically, the operation called "squaring on" means the adjustment of the optical axis of the objective until it passes accurately through the centre of the eye-piece. If the objective is not "squared on," its optical axis falls more or less to one side of the centre of the eye-piece, and we have the condition of things shown in Fig. 1, where $o-a$ is the optical axis of the objective, falling to one side of the eye-piece, so that the latter is looking obliquely at the objective, as it were. It is impossible for all the rays passing through the objective to focus accurately to a point on the oblique axis $o-a$, whatever the type of objective may be, although, as will be pointed out further on, there is one type which renders possible a nearer approach to good definition on an oblique axis. If the objective is "squared on," the optical axis $o-a$ will now be transferred to the position $o-a$, passing centrally through the eye-piece.

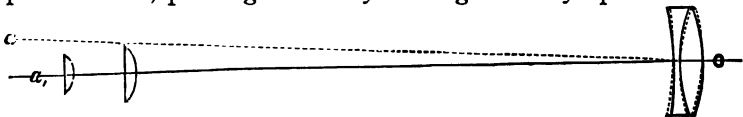

Fig. 1.

The symptoms resulting from any such maladjustment of the objective are strikingly evident if the objective is tilted to any very serious extent ; but if only to a very slight extent, then the observer will need very careful and discriminating exercise of his eyesight in order to give the final touches to the adjustment. It must be remembered, also, that an objective must be carefully "squared on" before the observer is in a position to form a just estimate of the quality of the glass, that is unless it is a very bad one ; for there is no type of object-glass in existence which will give a perfect image of a point of light or star at a point situated even half a degree only from the optic axis : for, in the first place, the oblique image is never a round star disc, but a sort of linear formation caused by the astigmatism which mars the oblique performance of refractors and reflectors in equal degrees. But, besides this inevitable astigmatism, there is also an oblique effect, known as "coma" or eccentric flare, whose amount very essentially depends upon the form of the object-glass. This defect is superimposed upon the inevitable astigmatism, and in many cases is violent enough to completely disguise the latter.

In accordance, then, with the dependence of coma upon the forms of object-glasses, the latter may be divided, very conveniently for our purpose, into the classes whose several behaviours when tilted or thrown out of square are different, thus requiring different treatment.

1st. There is the largest class, including objectives such as are represented in cross section in Figs. 2, 3, 4 and 5. Taking them in their order, Fig. 2 represents a type having a meniscus crown and biconcave flint, thus offering the great practical advantage of three concave surfaces which can be accurately and separately tested. But it has the great practical disadvantage of giving a very limited field of view, the image deteriorating rapidly on leaving the optic axis, and therefore, as a corollary from this fault, the objective is very sensitive to a slight amount of tilting which would have no appreciable effect upon some of the other forms. For all the objectives (Figs. 2, 3, 4 and 5) included in this class give a lateral image which is characterised by inward coma, or coma in which the flare lies inwards towards the optic axis ; and they yield this effect in degrees depending directly upon the degree of outward bulge of the curves of the object-glass.

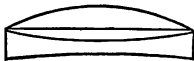

Fig. 2.

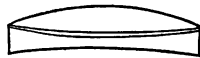

Fig. 3.

Fig. 3 represents a form in which the crown lens is arranged to give the minimum amount of spherical aberration consistent with its focal length. It is what is called a lens of the

“crossed” form. If of ordinary crown-glass, its radii of curvature are nearly as 1 to 6 or 1 to $7\frac{1}{2}$. This form has the disadvantages of the last form, but in a minor degree:

Fig. 4 represents the form of double-objective which we generally adopted ourselves. The radii of the crown lens are to one another as 2 to 3, while the flint curve next to the crown is at the same time represented by 2'815 (provided the indices of refraction for the D ray are 1'518 and 1'620 respectively), while the fourth surface is a concave of long radius. The advantages of this form are, the least possible sensitiveness to being tilted or thrown out of square, and the largest field consistent with the retention of two concave surfaces, the latter being an important advantage in practice. Also, the correction for spherical aberration is almost wholly due to the inside surface of the flint lens, leaving an exceedingly small residual aberration to be corrected by the refraction at the fourth surface. Thus the radius of the fourth surface can be altered at will to correct for chromatic aberration without disturbing the correction for spherical aberration.

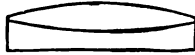

Fig. 4.

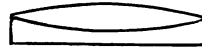

Fig. 5.

Fig. 5 shows a form of objective in which the crown is equi-convex or thereabouts, while the fourth surface of the flint is flat or slightly convex. Sometimes the two inside curves are similar and may be cemented together. This form introduces unnecessary practical difficulties, although it is still less sensitive to being thrown out of square, and offers a rather larger field than any of the preceding; but in large instruments where the field observed generally is very small relatively to the size of the instrument, this ceases to be an advantage of any weight.

2nd. There is the type of double objective shown in Fig. 6. It necessarily varies according to the optical characteristics of the glass used, but the chief feature of this form, which puts it in a class by itself, is the fact that it yields the maximum field of view obtainable and relative excellence of image for some considerable distance from the optical axis.



Fig. 6.

It is this type of objective which is most eminently suitable for photographic purposes, where the chief desideratum is the largest possible field of view consistent with the aperture.

In other words, such an object glass as this is quite free from coma in its oblique image. There is simply astigmatism of a symmetrical character.

The mathematical conditions to be fulfilled in an object glass that shall be free from coma will be found dealt with in a paper by Mr. H. Dennis Taylor, entitled "Telescope Objectives for Photographic Purposes," in *Monthly Notices of the Royal Astronomical Society*, Vol. LIII., No. 6.

But if a large objective of such a type is used for visual purposes where high magnifying powers are used, it will be attended by certain serious mechanical disadvantages (to be noticed further on) over and above the extra difficulty involved in making a *perfect* objective with three convex surfaces. As an instance of the ratios of curves it may be noted that if a certain peculiar hard and colourless, yet low refractive crown, made by Schott and Gen, of Jena, is used for the crown lens, and ordinary light flint for the flint lens, then the curves are in the following ratios, in order to fulfil very closely the above-mentioned condition for large field, and to bring the chemical rays about as nearly as possible to one focus, the ratio of aperture to focal length being $\frac{1}{10}$. If the radius of first surface is 5, then that of second ditto is 3, the third 3.05, and fourth 25.

3rd. There is a form of objective rather resembling the last type, but its curves are carried to a still further extreme of bulge towards the eye-piece, see Fig. 7. This form has not the advantage of a large field in the same degree as the second type, while its disadvantages are more pronounced, so that it is difficult to see why such forms are made, unless it is that the makers are really aiming at an objective of the second type (Fig. 6) and fail to realise it.



Fig. 7.

Such forms of objectives with their curves decidedly bulged inwards towards the eye-piece yield outward coma in their oblique images. The eccentric flare lies outwards away from the optic axis.

It may be said that the type of objective shown in Fig. 6 occupies a place by itself, dividing the first type, characterised by outward bulge of the curves and inward coma, from the third type, characterised by excessive inward bulge of the curves and outward coma.

Of course, the appearances to be looked for when an objective is out of square vary according to which of the three types the objective in question happens to belong, and the adjustment is different in each case. In five cases out of

six an objective will doubtless be found to belong to the first type, and the following is the method to be pursued for all such objectives.

In the first place it is supposed that all good objectives of over three inches in aperture are provided with certain screws whereby the cell or mounting may be tilted until the optical axis is caused to pass centrally through the eye-piece. The method generally adopted for ordinary sizes is shown in Figs. 8 and 9, which are respectively a cross section and a plan of a cell and its attachments such as we generally used to supply ourselves. In Fig. 8 the shaded section represents the cell holding the object glass. It is attached to the counter-cell c by means of the three bayonet joints b . When the cell is slipped over the three screws b and then rotated so as to bring the narrow ends of the bayonet slots under the screw-heads, the latter are tightened up and the cell is fixed. But the counter-cell c , carrying the cell within it, is capable of a tilting movement with respect to the fixed flange f - f by means of the three pairs of counter-screws shown at s, s_1, s_{111} . On examination it will be found that, of each pair of counter-screws, one (1) is threaded through the flange f and pushes against the counter cell c , its office being to keep them separated by any interval, while the other (2) passes loosely through the flange f , but is threaded into the counter-cell c , its office thus being to draw the counter-cell nearer to the flange f . It is obvious that when both screws are tolerably tight they exert opposite effects and hold the counter-cell rigidly at any fixed distance (within limits) from the fixed flange f . For convenience we will call (1) the pushing screw, for when tightened it tends to push the counter-cell further out at that point, and the other (2) the binding screw, as it tends, when tightened, to draw the counter-cell flange *nearer* to the fixed flange.

If it is desired to bring the counter-cell a little nearer the flange at any point near a pair of counter-screws, then the pushing screw will have to be relaxed (by a lever), and the binding screw tightened or screwed home until the resistance of the pushing screw, again coming into operation, causes the binding screw to feel tolerably tight again, when further tightening should be desisted from. To *increase* the separation between the counter-cell and flange at any point at or close to a pair of counter-screws will, of course, require the binding screw to be sufficiently relaxed or unscrewed first, the pushing screw being then screwed home until of the proper tightness.

By referring to Fig. 9 it will be seen that if the objective has to be pushed in wards (towards eye-end), near the screws s_{111} , it may be done either by bringing the flanges nearer together at s_{111} by means of those counter screws,

or, if a nearer approach of the flanges is impracticable, then the same effect will be produced by pushing *out* the objective at a point opposite to s_{111} and this may of course be effected by separating the flanges by means of both

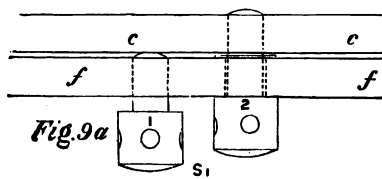
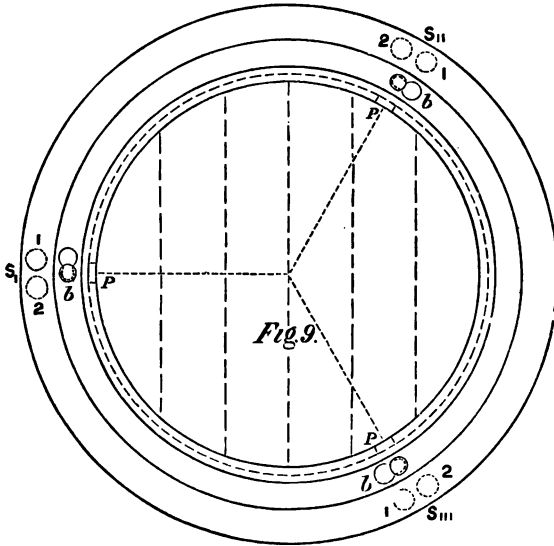
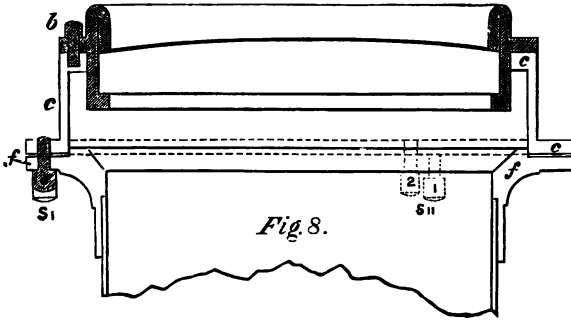

pairs of counter screws s_1 and s_{11} , the adjustment being equally divided between them.

Or, again, if the counter-cell should require pushing off at or near s_1 , it may be done either by means of the screws s_1 , or by pushing in by means of the two pairs of counter-screws s_{11} and s_{111} , dividing the adjustment between them. In order to get at these counter-screws, in the case of some telescopes, it may be necessary to remove the dew-cap.

If it is desired to see whether the objective is correctly adjusted or not, the telescope should be directed to some moderately bright star at a good altitude and its image brought to the centre of the field of the eye-piece, which should be of medium power. However good the objective may really be, no really sharp image of the star will be obtained if it is much out of adjustment. If the *O.G.* is of the first type, then the best possible focus will show a fan shaped appearance like Fig. 10 (c)* of very appreciable size instead of a minute spurious disc. And if the eye-piece be racked in and out of focus alternately the star's light will then be noticed to spread out into a more or less pear shaped luminosity, the smaller end being the brightest. This appearance is similarly situated whether the eye-piece is within focus or beyond focus, and is caused by the objective being too near to the eye-piece at that side corresponding to the smaller and brighter end of the pear shaped appearance. Thus if the latter shows towards the observer's left hand, as in Fig. 10 (a), the fault may be corrected by the counter cell being pushed further out at the corresponding left hand side or by being pushed in on the side opposite. The pear shaped luminosity depends on the fact that if an objective of the first type is tilted out of square, then the rays passing through near the edge which is nearest the eye-piece (say the point s_1 in Fig. 9) will have the shortest focus, while, roughly speaking, the focus will lengthen successively according to the parallel chords shown in dotted lines until the opposite edge is reached where the objective has its maximum tilt outwards, and the rays pass through to the longest focus. But the best thing to direct the attention to, especially during the more delicate stages of squaring on, is to note carefully the position of the star when in the best possible focus, and then, on racking out of focus suddenly (either outwards or inwards or both), note that the more or less round disc of luminosity which results does not spread out symmetrically round the position of the star when in focus as a centre, but expands itself more or less to one side of the star's position. In Fig. 10 (a), the bulk of the luminosity has developed

* Figs. 10 to 24, inclusive, are represented by photography in the frontispiece.

itself towards the right hand of the position of the focussed star, which is marked by a small cross. Therefore the objective needs pushing inwards (towards the eye-piece) on the right hand or else outwards on the left hand (looking from the eye-end).

One whole turn of each of the counter-screws operated will perhaps be found about sufficient to correct the error. The telescope should again be directed to a star, preferably a smaller one and near the zenith, and another examination made of the image when in the centre of the field.

It will most probably be found that there still exists a little outstanding error. Using a high magnifying power it may now be found that the luminosity still expands itself somewhat to one side of the position of the focussed image, as in Fig. 11, and if the fault is slight it will require very careful and discriminating use of the eyesight to observe it, and it will also be necessary to rack in and out of focus only to a very small amount, as a little practice will suggest. Moreover, a much more delicate manipulation of the counter-screws will be necessary when making the last adjustment.

The least experienced of observers will have noticed before this that the luminous disc, visible when a star is thrown out of focus, is not of continuous brightness, but is broken up into a system of interference rings; the farther out of focus and larger the luminous disc, the greater is the number of rings visible. During the last stages of squaring on, it is important to bear in mind that the remaining want of adjustment in the objective will be most readily detected if the observer is careful not to throw the image more out of focus than will cause one or two rings to become visible when using a high-power eye-piece. The least disposition of the rings to expand somewhat to one side of the focussed star may then be detected and the corresponding minute adjustment of the proper counter-screws effected. With care, the observer will still be able to notice that that part of the luminous disc (or rather *ring*) which expands the farthest away from the star's place is least luminous, while the opposite side which corresponds more nearly to the star's place is the brightest part (*see Fig 11*). However, the characteristic of *eccentric expansion* of the rings is the best thing to observe in practice.

For objectives of the first type then, the rule is,—the objective requires pushing in nearer to the eye-end on that side of it corresponding to the direction of eccentricity in which the luminosity or ring system yielded by a star out of focus expands relatively to the position of the same star when in focus. Or, as an alternative, the objective may be pushed off, away from the eye-end, on the side opposite to the direction of eccentricity.

It is usual in some Text Books on Astronomy, when dealing, far too shortly, with this subject of squaring on an objective, to instruct the observer to note very carefully the conformation of the star image when in focus under a high power, when, if the objective is out of square, the spurious disc will not be round but oval, with the two or three slight diffraction rings which should surround it thrown to one side only of the star disc. This would indicate that the objective needs pushing in on that side towards which the diffraction rings show themselves. For instance, if the star shows an appearance like Fig. 10 (*b*) with the rings lying towards the right, the inference is that the objective needs pushing in towards the eye-end on the same side, or right hand when looking from the eye-end. This method may certainly be followed, but in practice it is far inferior to the method we have described above, for the principal reason that it requires an exceptionally good observing night, at any rate with large instruments, to enable a close scrutiny of the spurious disc and its rings to be made. The observer might get his objective approximately right on an ordinary night, but on a much finer night ensuing he would most likely find that his squaring on was not final after all. Whereas, if the observer puts the method which we recommend carefully into practice on an average observing night, he will be able to adjust the objective in much less time, and when it is done he will find that it will successfully pass the other test when applied on a really fine night, and will show the spurious disc and the diffraction rings symmetrically surrounding it, as in Fig. 12 (*a*), that is, if the objective is a really perfect one.

If the telescope is a large one and the tube has to be turned down, eye-end upwards, every time the objective is to be adjusted, the observer may easily make a mistake and turn the wrong counter-screws unless he takes the precaution, when he is examining the star image and finds it expand eccentrically when out of focus, of noting in which direction the eccentricity falls with regard to some fixture upon the telescope tube. For instance, the direction of eccentricity may be towards the finder, away from the finder, at right angles to the same, or towards the declination axis, or a direction half-way between the finder and a declination clamping-handle, etc. Thus, when the tube is turned object-end downwards, the observer has only to look for guidance to such prominent parts of the telescope in order to see whereabouts the objective needs pushing in or off.

When the objective has been finally adjusted it will be found, on examining the image of a small star, that the luminous disc or ring system will expand itself concentrically with regard to the position of the star when in focus, as in

Figs. 12, *a*, *b*, *c*, *d* and *d*₁, where a little cross marks the position of the star when in focus. This point is the only one to be regarded *at present*, for it may be found that although the luminous disc expands itself concentrically with regard to the focussed image, nevertheless the disc of light is not round but appears oval (*d* and *d*₁), or even of some irregular shape (*c*). Such appearances are indicative of defects either in the objective or in the eye of the observer, or both. Further on we will give full directions for finding out where such defects really lie, and for enabling an observer to form a very good idea of the optical quality of his instrument.

We have now given directions for the adjustment of all objectives included in the first type. It may be pointed out again that an objective like Fig. 2 will need a more delicate adjustment in squaring on than Fig. 3, still more than Fig. 4, and more still than Fig. 5. An amount of tilting of say $\frac{1}{10}$ inch would cause a less and less serious effect at the foci of these four varieties of objective according to their numerical order.

But on coming to our second type of objective, shown in Fig. 6 and specified above, it will be found that it does not follow the same rule as the first type does; for, if it is considerably tilted, it will be found that the luminous disc yielded by a star when out of focus, will still expand itself symmetrically round the position of the star when in focus, but it will appear more or less oval in shape, as in Figs. 12 (*d* and *d*₁), which represent the appearance at opposite sides of the focus, the major axis of such oval, when inside focus, being parallel to the axis about which the objective is tilted, while, beyond focus, the axis of the resulting oval is at right angles to the last position. This defect of astigmatism for oblique pencils is, however, not so great as to prevent this type of objective being the most eminently suited for photographic work where a relatively large field of view is required. If an objective of this type is examined as to its adjustment, and the observer finds, when using a high power on a star, that the luminous disc is an upright oval inside focus, and a horizontal oval outside focus, and if he has satisfied himself that such appearance does not result from a defect in his eye (by a simple method yet to be explained), but is caused by the objective, then either the objective is inherently defective, or else it requires "squaring on." If the latter is the case, it must be effected by tilting the objective about a vertical axis, by pushing in on the right and pushing off on the left, or *vice versa*, for nothing but actual trial will show which of these opposite movements is required. If the appearance inside focus were a *horizontal* oval, then the tilting would have to be done about a horizontal axis, and so on.

But if the astigmatism cannot be removed by any such tilting movement, the conclusion is that the objective itself is at fault.

As to the third type of objective, as Fig. 7, it will be found that its behaviour, when thrown out of square, is just the opposite of that exhibited by objectives of the first type. Therefore, when the luminous disc is seen to expand itself eccentrically with regard to the focussed star, the defect is to be remedied by the objective being *pushed off* on that side of it towards which the eccentric expansion takes place. If the luminous disc expands towards the right of the star's position, then the objective must be pushed out away from the eye-end on the same side, or else pushed in on the opposite side; that is, it requires just the opposite treatment to that required for the first type.

The operation of squaring on an objective need not occupy much more than an hour in the case of large instruments, provided the weather allows uninterrupted views of stars of considerable elevation. For telescopes without clock-work, perhaps there is no more favourable star for the purpose of squaring on and subsequent testing than the Pole Star. The operation is easy in practice, at any rate up to a tolerable degree of exactness. As it requires a very careful use of the eyesight, especially in the nicer stages, the observer should try to be as comfortable as possible when examining the focus, a strained position being so much against exactitude of observation. Again, a residual amount of maladjustment of the objective will generally escape the notice of a beginner, let him exert his eyesight as he will; yet, after he has grown used to his instrument and trained his eye to look out for indications of maladjustment, he will become very much quicker to notice them, and, if he takes pride in a good instrument, he will also be quick to correct them, for a really good objective cannot give its best definition under high powers while any noticeable error in squaring on exists.

After an objective has been correctly "squared on," the observer may then turn his attention, if he likes, to forming a judgment of the optical quality of his instrument, and we will now give directions and illustrations of the methods which will enable him to do so, at any rate with substantial accuracy. All the following remarks apply impartially to *all* the older types of double objectives without distinction, so long as they are used for ordinary astronomical observations, in which case the image is viewed by the eye through eye-pieces of considerable magnifying power. But they would not apply to an opera glass objective at all, and only in a less strict degree to an objective used for photographic purposes in the camera, in which case the image is not submitted to the scrutiny of such high powers.

ACHROMATISM.

Perhaps the first thing to direct the attention to in testing an objective is the state of its achromatic correction. With comparatively few exceptions the eye-pieces used with astronomical telescopes are either Ramsden's or Huygenian eye-pieces, generally the latter, and it is necessary first to explain that the power of an eye-piece exercises a quite perceptible effect upon the apparent achromatic correction of the telescopic image viewed through it. A very common misconception exists as to the real nature of the so called achromatism of such eye-pieces. They are only achromatic in the sense of treating pencils passing laterally through them from the edge of the field in the same manner as an axial pencil; they treat central and marginal pencils of light impartially, and so far they are achromatic. When such an eye-piece is used upon an absolutely achromatic image, such as that yielded by a reflector, the effect is this. In the first place an axial pencil passing perpendicularly through the centres of the lenses consists on emergence of variously coloured pencils having a common axis, that is, all the coloured pencils seem to come from the same direction, but they do not emerge as though all coming from the *same point* on their common axis, as they would do were the eye-piece achromatic in the ordinary sense. For instance, if the blue green rays about F emerge strictly parallel, then the orange red rays about C will at the same time emerge in a state of divergence. In the same way, a white pencil forming a point near the edge of the image will, after passing through near the edges of the eye-piece lenses, emerge in such a manner that the coloured pencils of which it is composed seem, as before, to come from the same direction, but again they do not emerge as if coming from the same point in that axis or direction; if F rays are parallel, as if coming from a point at an infinite distance, then C rays will be divergent, as though coming from a near point in the same direction. Therefore the image from a reflector viewed through such eye-pieces will not look perfectly achromatic, but more or less under-corrected, and such want of achromatism will show itself almost impartially all over the field, and it is just this latter feature of its behaviour which gives the eye-piece its title to being called achromatic. For it is obvious that if the image were viewed through a single lens of a focal length equivalent to that of the Huygenian eye-piece considered, and the eye placed at such a distance behind such lens as to command a view of the whole field at once, then the image of a star in the centre of the field would show just about the same amount of colour as the same star would do when viewed through the Huygenian eye-piece, but the images of stars

towards the edge of the field would appear very indistinct through the single lens, being drawn out into coloured spectra of a length increasing as the edge of the field is approached, and all longitudinally pointing their red ends to the centre of the field.

Supposing the *eye* to be achromatic, it can be shown that the colouring effects due to Huygenian or Ramsden eye-pieces, as seen by the eye and measured by the standard of the spurious disc or real image, vary in direct ratio to the equivalent focal lengths of such eye-pieces, and while the colour effects of eye-pieces of high power may seem but slight, still the coloured fringes produced by eye-pieces of lower powers become decidedly aggressive to a fastidious eye.

But the most cogent proofs may be brought forward to show that the human eye falls far short of being achromatic. Now this imperfect achromatism of the eye is a factor of great importance, often overlooked, in its bearing upon the apparent achromatism of telescopes under varying magnifying powers. If an observer will examine the image of a star yielded by a reflecting telescope, using a series of Huygenian eye-pieces, the lowest power being such as to transmit a pencil of light into the eye which shall have a breadth sufficient to fill the pupil of the eye (the magnifying power necessary to do this is obtained by dividing the aperture of the mirror by the diameter of the pupil of the eye), he will find there is a very perceptible amount of red fringe round the image of the star as seen under the low power, and it is specially noticeable if the eye-piece is racked a little way within focus. If successively higher powers are applied, it will be noticed that this red fringe or appearance of under correction for the most part disappears, so that under a very high power only a very small trace relatively of red fringe will remain. The larger amount of colouration noticeable with the low power is really due to both the eye and the eye-piece. Given the fact that the eye is not achromatic, it is evident that its dispersive effect upon any ray will be greater if it is refracted through near the edges of the pupil and the lenses of the eye than if it is refracted through nearer to the centre of the eye, and therefore a pencil of light such as emerges from a low power eye-piece and is broad enough to fill the pupil will suffer far more from the eye's want of achromatism than will the very narrow pencil (perhaps under a fiftieth of an inch in breadth) which emerges from a high-power eye-piece. If the observer will then dispense with an eye-piece altogether, and look at the image of the star direct and then approach his eye towards the image until it goes out of focus and swells out into a disc of light, he will then see a considerable amount of red fringe similar in character to but less in amount than what he saw when using the low-power eye-piece; this will

give some idea of the amount of colouration due to the eye alone (for there can be no question concerning the perfect achromatism of the star image yielded by a reflector).

Then again, the relation existing between the aperture and the focal length of the object glass or mirror exerts a most marked influence upon the amount of coloured fringes produced by both eye and eye-piece, that is supposing that the powers used are high enough in all cases to pass the whole of the light from the objective or mirror through the pupil of the eye. For it is evident that with a given eye-piece in use giving a certain magnifying power with a certain focal length, the doubling of the aperture of the objective or mirror leads to the doubling of the breadth of the pencil of light passing through the eye-piece and also through the eye, and, therefore, the more colour producing edges of the lenses of both eye-piece and eye are brought more into operation. Indeed, the mischievous effects of the coloured fringes produced by doubling the relative aperture of the objective or mirror are quadrupled in amount when estimated in terms of the size of the spurious disc forming the real star image, which, as has been hinted at above, should always be taken as the standard of measurement of the subjective amount of chromatic and other aberrations. For while doubling the aperture or angle of the cone of rays has led to *doubling* the circles of confusion in different colours produced upon the retina, it has simultaneously led to the *halving* of the size of the star disc, in accordance with the well-known law of the size of the spurious disc forming the image of a star varying in inverse ratio to the aperture. Therefore, the coloured fringes are quadrupled in size as compared with the star image.

In the case of the refracting telescope, besides the coloured fringes produced by the eye-piece and the eye behind it, there are the coloured fringes produced by the objective itself. No one who has used even a three-inch objective upon celestial objects can have failed to notice the blue fringe of light surrounding all bright objects. The red fringe seen surrounding the penumbra of light when the eye-piece is racked inside the focus of a star, and the patch of concentrated red, and of more diffuse blue light seen about the middle of the penumbra of light when the eye-piece is racked outside of focus, are effects well known to all who critically examine their instruments. Indeed, the ordinary double objective can only be described as achromatic in an approximate sense. The double objective has been used down to this day in much the same condition that Dolland left it, and to those who are aware of the very imperfect concentration of only a portion of the coloured rays constituting white light into one focus by double objectives, the great work done by such

instruments, and their very satisfactory although not perfect defining power, must remain a matter of great surprise.

Such objectives made of ordinary crown and dense flint glasses yield a focus, for white light coming from a distant point of light such as a star, which may be described as the spectrum doubled back upon itself. It is the aim of the optician to so correct such an object glass that those rays to which the eye is most sensitive shall be refracted to the minimum focus, or the focus nearest the objective. These are the yellow, citron and green rays. Then the bright red rays about *B* or *C* are refracted to a focal point somewhat further off the objective, along with the greenish blue rays about *F*. The duller red light at the end of the visible spectrum has a still longer focus, and the blue rays beyond *F* a still more extended focus, and the violet rays are refracted so far beyond focus as to be almost beyond recognition. Hence, if a white object such as a planetary disc is focussed in such a telescope, there is a fairly sharply defined image thrown upon the retina painted by the most luminous rays of the spectrum, the yellow green principally, while the green and bright blue light, along with the full red and dull red, form a halo of wasted light round the object, and this constitutes the secondary spectrum as known to the observer. For fuller information upon this very interesting subject, and for an explanation of why it is that these colour aberrations do not absolutely destroy definition in the case of large refractors, we will refer the reader to Mr. Dennis Taylor's paper on "The Colour Aberrations of the Refracting Telescope in Relation to Vision," reprinted in the appendix, and also to his paper entitled "An Experiment with a twelve-and-a-half-inch Refractor, whereby the light lost for defining purposes owing to the secondary spectrum is separated out and rendered approximately measurable." (Memoirs of the Royal Astronomical Society, vol. LI.) In this experiment, the loss of light theoretically arrived at in the paper reprinted herein was practically confirmed.

It is of course highly important in the case of large refractors that the best and most achromatic image should be thrown upon the retina when the higher powers are used, as when making delicate observations on stars and planets; it is, therefore, usual to aim at such a colour correction in the objective as will permit of this result. With a magnifying power of 50 to 70 times the aperture (in inches) a good objective should give a retinal image as perfectly achromatic as is theoretically possible with the materials at command. It is evident that the objective must be absolutely a trifle over-corrected for colour in order to counteract the want of achromatism in an eye-piece of such power combined with that inherent in the

eye, for, as we have seen, their combined effect is to cause a truly achromatic pencil to appear under-corrected for colour. But it is not quite so evident that this amount of over-correction in the objective will not suffice to counteract the effects of eye-piece and eye when lower powers are used, and that it will be more than enough to counteract the same when a higher power is used. But such is the case. If the conditions of vision and the effect of the eye-piece are taken into account, it can be theoretically proved that the most perfect achromatism of the retinal image can be obtained with only one magnifying power, which may be selected. And this fact has to be allowed for when testing an objective for its achromatic correction, as we will shortly explain.

There is, perhaps, no better star for testing the colour correction of objectives of moderate and larger sizes than the Pole Star. If the telescope is directed to this star and the image examined with the magnifying power we have specified, then the appearances to be looked for, if the objective is nicely corrected, are a greenish yellow disc or ring system surrounded by a very narrow red fringe when the eye-piece is racked inside focus sufficiently far for two or three rings to be visible. The corresponding appearance when outside focus are the same greenish yellow disc, but without any trace of a red fringe, but, perhaps, a trace of a green fringe. Moreover, if the observer racks out of focus with great care, he will be able to notice a little bright red star disc, which forms itself just as the main focus is beginning to perceptibly expand. This is the focus for the less refrangible red rays beyond C.

On racking outwards a little further, an indefinite blue focus will begin to form itself in the centre. And on going further out still, until six or more rings can be counted, there will be a blue flare superimposed upon the greenish yellow ring system; it will about cover all the inner rings, scarcely reaching to the outer ring, while it grows brighter and more violet towards the centre of the system.

If the telescope is now directed to a blueish white star, like Vega, still keeping the same eye-piece in use, it will be found that there is now scarcely a trace of a red fringe to be seen when inside focus. The light from stars of this type is deficient in the less refrangible of the red rays. On the other hand, if the telescope is directed to a ruddy star such as α Orionis, it will be found that the red fringe visible when inside focus is very strongly marked, very much more marked than in the case of Polaris. These ruddy stars are comparatively rich in the less refrangible of the red rays. This is mentioned chiefly because many observers, looking at ruddy stars when trying their telescopes, might otherwise

conclude that the objective was under-corrected, when really as achromatic as possible.

Turning to Polaris again, let the effect of changing the eye-piece be observed. Supposing the achromatism to have been as perfect as possible under a magnifying power of 50 times the aperture, let an eye-piece magnifying about 100 times aperture be substituted. On racking inside focus it will be found that not a trace of a red fringe is to be seen; indeed, the objective would seem to be over-corrected (as in fact it is). If lower powers are substituted it will be found that the red fringe when inside focus will grow more and more conspicuous in proportion to the focal length of the eye-piece, and the objective will appear more and more under-corrected, until a magnifying power equal to the aperture divided by the diameter of the pupil is reached, when the apparent under-correction will be at its maximum.

Therefore, it is not fair to test the achromatism of an objective with any eye-piece that happens to come to hand, or upon any star taken at random, unless the observer knows, at least approximately, how much to allow for the apparent effect of such eye-piece, or for the prevailing colour of the star.

FALSE CENTERING.

When the two lenses composing an objective are either untruly edged, or so badly fitted in the cell that their optical centres are thrown out of coincidence, then the effects at the focus are serious, and may easily be detected. For, if the eye-piece is racked somewhat inside of focus, it will be noticed that more red shows upon one side of the ring system than another, and moreover, any bright object in focus will show a red edging more or less marked upon one side, and possibly a greenish fringe on the opposite edge. In either case the implication is that the centre of the flint lens is displaced relatively to that of the crown, in a direction corresponding to where the red fringe shows the most strongly. For instance, if the red fringe shows to the right, it means that the centre of the flint lens is displaced somewhat to the right of the centre of the crown lens. If the error is very serious the image of a star will be drawn out into a sort of spectrum. When testing for this fault it is highly important to direct the instrument to a star near the zenith, so as to guard against atmospheric dispersion. For a perfectly centred objective, if directed towards a star near

the horizon, will not give an achromatic image, but it will appear drawn out into a vertical spectrum, with its red end showing uppermost. And even at intermediate altitudes a large telescope, although correctly centred, will show a star image which is perceptibly more red at its upper margin. If required, this atmospheric dispersion may easily be corrected by looking through a very slight prism, placed behind the eye-piece, with its thin edge uppermost.

Indeed, if the amount of eccentric colour is only small an experienced observer knows how to neutralise it when using high powers simply by altering the position of his eye. In the normal course of things it is supposed that the centre of the pupil of the eye is placed exactly in alignment with the optic axis of the eye-piece, and in such a case of course any colour fringes due to the eye are distributed evenly around the image. But if the pupil of the eye is displaced laterally so that the pencil of light emerging axially from the eye-piece is forced to traverse the pupil of the eye eccentrically, then eccentric colour effects are at once produced. For instance, let a star or planet be focussed nicely in the middle of the field of view of a rather high power eye-piece, then, if the eye is properly placed behind the eye-piece, whatever coloured fringes are seen are distributed impartially around the object, but if the eye is moved towards the right hand, it will be noticed that the right hand margin of the object becomes decidedly redder than before. This in itself exhibits the imperfect nature of the colour corrections of the human eye. An experienced observer may, however, turn this little fact to account by acquiring the knack of so looking through his telescope as to largely counteract small colour aberrations due to atmospheric dispersion or imperfect centering.

If the lateral displacement of the eye were carried still further so as to cause the emergent pencil of light to be roughly bisected by the edge of the opaque iris, thus only allowing to pass into the eye the pencil of light transmitted by about half of the objective, then the secondary spectrum of the objective would at once obtrude itself in an aggressive manner, in the shape of yellow green fringes at one side and purple fringes at the other side of objects. This is especially noticeable in the case of refractors of relatively short focal lengths. Altogether there is little doubt that the clearness of vision through a telescope depends in no small degree upon the way in which the observer applies his eye to it. The observer who applies his eye eccentrically and capriciously to a perfectly adjusted refractor may easily delude himself into believing that one of the lenses is out of centre, whereas the observer who has acquired the proper knack of looking can always get the best out of his instrument.

ASTIGMATISM.

The perfect fulfilment of the condition that all rays striking the objective at equal distances from its centre shall be equally refracted, is of primary importance. If the objective refracts two rays, incident at opposite points on the same diameter, and equidistant from the centre, more strongly than rays incident upon corresponding points along a diameter at right angles to the former, then the objective is said to be astigmatic. The violation of the above condition is more serious than any other. Let that diameter of the objective be selected at the extremities of which the strongest refraction takes place, and a plane be imagined which shall include both this diameter and the optic axis (we will call this the primary plane), and another (secondary) plane be imagined at right angles to the former, including the optic axis, and that diameter of the objective along which the weaker refraction takes place (and which is at right angles to the first diameter).

It will be seen that the effect at the focus, when the telescope is directed to a star, is a very peculiar one. The shortest focus is for rays in the primary plane, while in the secondary plane the rays have not yet come to focus. Therefore the effect is the formation of a short focal line in the secondary plane, whereas if the focus of rays in the secondary plane is considered, it will be seen that since the point where they come to focus is beyond the point where rays in the primary plane have come to focus, therefore the rays in the primary plane will have diverged again, and there is formed another focal line, about equal to the former one, only this time it is in the primary plane. So that the image of a star instead of being a minute round disc, like Fig. 12 *a'*, may show either as an elongated line in the primary plane, or a similar line at right angles to former, and in the secondary plane. Fig. 12 *d''* represents such an elongated star image. Which of these focal lines is seen depends simply upon which is focussed. It can be shown that a cross-section of the rays half-way between the two focal lines will be a circle, whose diameter is equal to half the length of either of the two focal lines; this is the circle of least confusion, and will in practice be the point actually focussed upon. As an example of the mischievous effect of astigmatism, let an objective be taken, six inches aperture and 90 inches focal length, and let it be supposed that the rays in the primary plane come to focus at a point $\cdot 02$ inches shorter than the rays in the secondary plane. Then the length of either of the two focal lines will be $\cdot 00133$, and the diameter of the circle of least confusion will be $\cdot 00066$,

and these amounts are respectively at least three and one-and-a-half-times the diameter which the spurious disc ought to have, were the telescope faultless. Fig. 12 *d*" represents the star image which would be seen if one of these focal lines were focussed upon, its larger diameter being about three times the lesser. With the same amount of astigmatism, the least circle of confusion would show somewhat like a star disc of about twice the proper size. Therefore such an amount of astigmatism would render the instrument useless for close double star observations. But, as we saw before in the case of achromatism, it is the perfection of the image *as thrown on the retina* which is all important, and therefore, even if the objective is perfectly free from astigmatism, it by no means follows that the observer will see *perfectly* well with it, because his *eye* may be astigmatic. As a matter of fact, astigmatism in a serious degree is a very common fault in the human eye, and, if present, may be easily detected by the observer himself. And now we will describe the symptoms of astigmatism, both in the telescope and in the eye, so as to enable the observer to discriminate between them.

It is best to select a star near the zenith, and of moderate brightness, so that there may not be too much glare. First use a very low power, and get the star into the centre of the field. On racking inside and outside focus, the luminous disc or ring system should appear perfectly circular. If it does not do so, but appears distinctly oval, with the major axis of the oval when inside focus at right angles to the major axis of the oval seen when outside of focus, then the inference is, *most probably*, that the observer's eye is astigmatic. Whether that is the case or not may be decided in this way. Supposing that the observer is lying with his head towards the north, and when *inside* focus the major axis of the oval lies in the direction of his two eyes (for example), he has then only to alter his position so as to turn his head towards east or west, and notice whether the major axis of the oval, *inside* focus, has gone round with him or not, whether it still lies in a direction joining his two eyes. If it does so, and the amount of astigmatism appears just as much as before, and has distinct reference to his own position, then it is conclusive evidence that the fault is subjective, and in his own eye. But if the appearances do not move round with his eye, but appear fixed with regard to the telescope, then the fault lies in the latter. As an extra precaution, the eye-piece had better be rotated to see whether the fault goes round with it or not. If it should do so, which is unlikely, then the astigmatism is in the eye-piece. If neither the eye-piece nor eye is at fault, then the objective is very defective; and its astigmatism must be very serious to be noticeable with so low a power. Or, again, the observer may find that the image appears to him to

be strongly astigmatic when he is in a certain position, while when he places himself at right angles to that position the astigmatism no longer shows, and the image seems round and faultless on both sides of focus. This means that there is astigmatism both in the objective and in the eye, but their relative amounts are such as to neutralize one another when the eye is in a certain position relatively to the telescope, while at right angles to that position the two amounts are superimposed and the astigmatic effect is doubled. Or astigmatism may show itself in degrees varying with the relative position of the observer, in one position seeming very bad, and in another only moderately bad. This indicates that the effects of astigmatic errors of the eye and the telescope are unequal, and therefore they never neutralize one another. The use of a very low power, as we have recommended above, is specially adapted for detecting any astigmatism in the eye, for the simple reason that the astigmatism of the compound lenses of the eye is the more evident the greater is the aperture of the eye in use. When a low power is used the pencil of light entering the eye is perhaps large enough to fill the pupil, and its whole aperture is put to the test, whereas if the magnifying power is a high one, the diameter of the pencil of light may not exceed one-fiftieth of an inch, and that amount will therefore represent the eye aperture in use. But a low power is of little use for detecting astigmatism in the objective, unless it exists in a very large amount. Therefore as high a power as the night will allow should be used for testing the objective for the same fault, and the same star near the zenith will be best for the purpose.

On throwing the image in and out of focus in the centre of the field, the luminous disc may appear oval. For instance, when inside focus the appearance may be like Fig. 13, while Fig. 14 represents the corresponding appearance when outside focus. If the observer will carefully note the direction of the length of the oval on one particular side of focus, and then alter his position to one at right angles to the first, he will then be able to see whether it rotates with him, thus indicating astigmatism in his eye, or keeps in a constant direction with respect to the telescope, in which case of course the objective is at fault. The astigmatism in his eye must be very bad in order to show any appreciable effect with so high a power, and in most cases any astigmatism will be found to exist in the objective, if at all. If such is the case the observer is not in a position to eliminate it as a general rule, for it may be caused by bad annealing, sometimes defective material, very often bad figuring, and sometimes by an imperfect method of mounting the objective in its cell, so that it is subject to mechanical strains. If the latter is the case, the observer may be competent to deal with it.

Sometimes astigmatism exists both in crown and flint lenses, and if to about equal extents, then by turning one lens round with respect to the other a position may be found so that the objective is almost, or *altogether*, free from astigmatism. Many objectives are marked upon their edges, indicating that they will perform at their best when corresponding marks come together.

We have particularly called attention to the means of detecting astigmatism in the eye because it is a very much more common defect than most people are aware of, and we have good reason to suppose that many observers are disappointed with good instruments because this defect, of which they are unconscious, prevents them obtaining that clearness of vision and seeing those things in the heavens which they had been led to expect. It is, therefore, highly important that astronomical observers should deliberately test their eyes for this fault, and, if they find it present, go to a competent oculist for appropriate glasses, which can be used either as spectacles or mounted in a cap to fit over the eye-pieces and capable of rotation according to the position of the observer. Defects of eyesight can thus be neutralised, and the utmost clearness of definition obtained by the use of any really good telescope. We ought also to point out the fact that in many individuals astigmatism is found to be *variable* in amount, one day the eye may be almost free from the defect and on another day it is present to a serious degree. If an observer finds this to be the case, it can be provided against by the use of a selection of cylindrical lenses of varying powers in the eye-piece caps.

SPHERICAL ABERRATION.

Of course any objective worthy of the name must have the spherical aberration of the crown lens completely counteracted by that of the flint lens, and whether this correction is made with great perfection or only imperfectly, may make all the difference between a really good objective and a third rate one. *

For detecting spherical aberration it is best to direct the telescope, after the objective has thoroughly cooled down (see page 42), to a star of moderate brightness, and examine the behaviour of the image under a moderately high power when it is thrown out of focus. If the observer racks sufficiently far from focus as to cause three or four rings to

* See page 70 for maximum aberration permissible.

be visible, that will be best for the purpose of detecting any well marked aberration, which will show itself in the form of a greater massiveness or brightness of the two outside rings, especially the outermost one, when on one particular side of focus.

If, on going within focus by racking towards the objective, it is found that the central rings look very feeble, while the edge rings, and especially the outer one, look massive and luminous, while, on racking out of focus, away from the objective, the appearances are complementary to the above, the central rings looking relatively brighter and the outer rings looking weak and poor in comparison to what they appeared when within focus, then the inference is that the edge rays fall short or come to focus at a point nearer to the objective than the focus for the central rays, or, in other words, there is positive aberration. Fig. 15 represents the appearance within focus in this case, and Fig. 15*a* the complementary appearance to be seen outside focus.

On the other hand, if the central rings, when inside focus, look about as luminous or even more so than the outer ring, which is thin and weak (like Fig. 15*a*), while on racking outside focus the complementary effect of a massive and luminous outside ring enclosing comparatively feeble central rings is observed (like Fig. 15), then the inference is that the edge rays cross the axis and come to focus at a point further from the objective than the focus for the central rays, and this is the fault of negative aberration. If the amount of the spherical aberration is very small it will best be detected by using a very high power and taking care not to rack further out of focus than will cause two rings, or even one ring, to be visible. If there is residual aberration it may be detected by the same symptoms as before, but they will be less marked. For instance, Fig. 16 may represent the appearance on one side of focus, and 16*a* the corresponding appearance on the other side, whereas, if the objective were perfectly corrected for aberration, the appearances at both sides of focus would be exactly alike (if differences of colour are neglected), as in Figs. 22 and 22*a*. As regards colour, it is as well to remember that the diffusion of a blue flare over the more central rings, when outside of focus, tends to increase their apparent brightness somewhat, so that if an objective is perfect, the outer ring, seen *inside* focus when several rings are visible, will appear in somewhat greater contrast to the interior rings than the same ring will do when the eye-piece is racked outside focus. If the images are viewed through strong yellow glass, which absorbs the stray blue light, then the appearances should be exactly the same inside and outside of focus, with the exception of a slight red fringe in the former case. Then again, if the image

appears perfectly free from aberration with a very high power, it will scarcely do so when a low power is applied, for the effect of using a large eye-piece is to cause an appearance of positive spherical aberration, the edge rays of a pencil appearing to fall rather short, but this effect is only just perceptible.

Thus aberration may exist in very various degrees. It may be so bad as to be evident to the merest tyro at observing, or in such minute quantity that the greatest experience in testing telescopes will be needed in order to say positively that it exists. Still, an ordinary observer should be able to detect it if it exists in a really serious degree.

ZONAL ABERRATION.

Apart from the aberration resulting from the edge rays and central rays not focussing together, there is another serious fault, which perhaps is the one most commonly met with in objectives. The fault is caused by an objective being divided into zones, greater or less in number, having different foci; thus several foci are distributed along the optic axis, causing the general focus to be indefinite and confused according to the amount of the evil, the effect upon definition being much the same as that produced by spherical aberration, although the latter is the worse fault of the two. The amount of mischief done to the definition may be measured by the length of that part of the optic axis along which the foci are distributed, that is, if the relative arrangement of the zones and their foci are the same. And an objective which is divided into ten zones, whose foci range over one-thirtieth of an inch of the axis, may yield far superior definition to one which is divided into three zones, whose foci vary by one-tenth of an inch. So that the existence of a large number of zones in an objective need not greatly interfere with definition, unless their foci vary very considerably, though, of course, the *finest* definition cannot be expected if they exist in any perceptible degree.

In order to detect zonal aberration, it is best to direct the telescope to a very bright star, with a moderately high power, and rack in and out of focus as before, only it is best to rack out until 8 to 20 interference rings can be counted, for the irregular zonal effect is most easily detected under such conditions. If the fault is present the interference rings will not appear regular or in harmonious gradation from the centre to edge of the system. Counting from the edge inwards, it

may be noticed, for instance, that the outer ring is poor and weak, while the next one or two appear disproportionately strong, the next two or three weak, while those close about the centre are strong again (see Fig. 19), while on going to an equal distance on the other side of focus the complementary appearance shown in Fig. 19*a* will be seen. Of course, there is great variety possible in such defects. Perhaps the commonest form of it is one in which the objective is divisible into three zones, the outer zone and the central part focussing pretty nearly together, while there is a zone lying between the centre and edge, and generally nearest to the latter, which focusses short of the focus for the rest of the objective. This effect is shown in Figs. 20 and 20*a*, which represent the appearances to be seen inside of focus and outside of focus respectively. Another common fault is indicated by the appearances shown in Figs. 21 and 21*a*, which are seen inside and outside of focus respectively. Here the objective is pretty well figured in its outer parts, but the rays about the centre focus distinctly beyond the focus for the rest. This is caused by one or more of the surfaces of the crown having a flattened area in the centre, or by the opposite fault in the flint.

The rule in interpreting such appearances is that a bright zone or area noticed when *inside* focus corresponds in position to a zone or area in the objective, which focusses short, while a bright zone or area noticed when *outside* of focus corresponds in position to a zone or area which focusses beyond the general focus.

All these different sorts of zonal aberration are due to imperfect figuring of one or more of the surfaces of the objective. But *aberration*, or the regular gradation of the error from centre to edge, may or may not be due to imperfect figuring. For, on the one hand, the radii of the spherical curves may have been calculated and worked to with the utmost nicety, with a view to neutralising all spherical aberration, and yet a failure result owing to imperfect figuring, which, while producing a regular curve, may yet result in something in the way of a parabola, or, on the contrary, an oblate ellipsoid.

On the other hand, it is possible that all the surfaces may be accurately figured and spherical, but, owing to a miscalculation of the radii, there is a very serious residual aberration, perhaps so serious that it is impossible to neutralise it by any deliberate deviation from the spherical curves in the direction of a parabola, or *vice versa*, which is practically attainable. As a matter of fact it seldom happens that the calculated radii are so accurately carried out as not to necessitate slight deviation from truly spherical curves in order to neutralise very small residues of aberration.

PERFECT FIGURE.

If all the conditions necessary to perfection are fulfilled in an objective and in the eye of the observer, it will be found that the ring systems, seen when a bright star is thrown out of focus, are perfectly circular in outline, while the individual rings grow gradually and regularly stronger and further apart as the outside ring is approached, this outer ring running a little out of proportion seemingly in its brightness and breadth.

Above all, the appearance and arrangement of the rings should be *exactly* the same on both sides of focus, if allowance is made for the blue flare which somewhat enhances the brightness of and disguises the more central rings when outside focus. Figs. 22 and 22a represent the appearances, inside and outside focus respectively, which should be seen under a high power, when the eye-piece is racked just sufficiently out of focus for two rings to become distinctly visible, while another is on the point of expanding in the centre.

Fig. 23 represents the appearance which will be seen when the eye-piece is racked so far in or out of focus as to render eight rings visible or thereabouts. It is under such conditions that any irregularity in the formations of the rings will be most easily detected. Fig. 23 scarcely does full justice to that exquisite softness and regular gradation of the interference rings which should be visible when viewing a large star (out of focus) through a perfect objective when the atmosphere is clear and steady.

As an observer gains experience in the use of an instrument, and especially if he often directs his attention to the essential points indicative of quality, he will in the course of time grow far more critical, and little indications of imperfections, casual or inherent, will become plainly visible to him, which were too subtle to strike his attention at first; for the testing of an objective needs the most careful and discriminating eyesight and close attention, although any cautious observer, guided by proper directions, may gain a very good general idea of the quality of an objective.

We can imagine the question being asked, "What is the need for all this throwing the star image in and out of focus, and examining the appearance of the interference rings, etc., when what we are chiefly concerned with is the quality of the image *when in focus*; as long as the objective is seen to give fine definition, why should we care about the appearances of the image when it is *out of focus, and consequently useless*?"

This question admits of several answers, the principal one lying in the fact that no objective will yield the most perfect possible star image unless the various tests which we have described are conformed to; if an objective successfully

fulfils these out of focus conditions, then the most perfect definition which is theoretically possible may be considered assured. Then again, most of the faults which we have alluded to are more visible to a trained eye, if the out of focus appearances are examined, than if attention is confined only to the actual focus. The principal reason for this is, that the weather does not, on the average, permit of a critical examination of the star image under a high power, the same flickerings which are sufficient to make it impossible to see the focussed star image distinctly, are not sufficient to obliterate the much larger ring systems which are visible when out of focus. They will appear unsteady to be sure, but the eye learns to discriminate between permanent features and casual distortions in the form and distribution of the rings.

Of course, if an observer is trying a telescope on a night fine enough to enable him to closely examine the star image with a high power, and he finds it faultless and answering to the description which we shall presently give, he may rest satisfied at once that he is looking through a first-class instrument, provided that he sees the same appearance in all positions of his eye. But if there seems to be something wrong with the star image, it will not be possible to say what the fault is, or where it lies, without making an examination of the out of focus appearances, unless the fault lies in astigmatism, maladjustment, or want of true centering of the lenses, for, on a steady night, these three faults may be identified at the actual focus.

THE STAR IMAGE.

Fig. 17 represents the "spurious disc" which is formed at the focus of a *perfect* objective when directed to a star, a star being practically equivalent to a mathematical point of light in being devoid of apparent dimensions. And yet the image of such star shows dimensions which are quite measurable under high powers. Its size depends principally or almost wholly upon the relation between the average length of a wave of luminous light and the aperture of the objective. Thus no amount of perfection in the objective can make the star image any smaller, although the presence of small imperfections will cause it to appear unnecessarily large or deformed. If the star image is examined carefully with a very high power, and on a really fine night, it will be found to consist of a neat round little disc of light, with a softened outline, and distinctly edged with red. Surrounding it, after a dark interval, is a thin bright ring, which is only seen by

glimpses in a complete state, and after another dark interval is another ring, which rarely seems complete and is much less bright. If the star is a very bright one, three or four rings may be counted, the outer ones being visible with difficulty and by glimpses. Theoretically, these rings should show colour, green on their inside edges and red on their outside edges, but it can rarely be seen except in the disc itself and the next and brightest ring. The wave theory of light offers a complete explanation of the formation of the spurious disc and the surrounding rings.

In a thoroughly well corrected object glass, with its optic axis directed to a star, the rays after passing through the lenses all proceed, as exactly as possible, towards the focal point f (Fig. 25). And if any spherical surface of any radius less than the focal length is imagined to be described about f as a centre, then such surface, where it cuts the cone of rays, will be a wave-surface, or a surface in which the ether particles are all exactly in the same phase of wave motion at any instant. Let $a-b$ represent a diametrical section of such a wave surface taken close to the object glass. Then, according to the wave theory of light, every point or ether particle along the spherical surface $a-b$ is itself a centre of light, tending to radiate light in all directions. Now, just provisionally, suppose that the aperture of the objective is square (Fig. 25a) with the diameter $a-b$. Then the spherical wave surface will be bounded by or contained in a square. It is evident that the ether vibrations, which start from all points of the spherical surface $a-b$ simultaneously and in the same phase, will reach the point f simultaneously and in the same phase, since f is in the centre of such spherical surface. Hence the great intensity of the light at the focal point f , resulting from the coalescence of all the rays arriving there in similar phase. But let a point d be taken at such a distance from f that the distance $b-d$ is greater than $a-d$ by an amount equal to a whole wave length of the light in question. That is, if a spherical surface is described about d as centre and with $d-a$ as radius, this surface will cut $d-b$ at c , such that the distance $b-c$ is equal to a whole wave length, and it follows, from the fact that $d-f$ is perpendicular to the optic axis, that the line of intersection of the two spheres (which line is shown in section at the point a) is a circle lying in a plane perpendicular to the plane of the paper and parallel to the optic axis $i-f$. Similarly, all lines of constant intervals between the two spheres will be circles in planes parallel to this first plane.

The wave surface $a-b$, if viewed in elevation from a distant point on the optic axis, will be the square shown in Fig. 25 (a). The side $g-m$ is the line of intersection of the two spherical surfaces described about f and d , and although part

of a circle, it must appear a straight line in Fig. 25 (a), because it is viewed from a point in its own plane. Similarly $i-g$ passing through the centre, is a line along which the interval between the two intersecting spheres is equal to half a wave length, for in Fig. 25 it will be seen that the intervals of separation between the two spheres are in direct proportion to the distance from a , because $a-c$ is equivalent to the curve $a-b$ rotated about the point a by an angle equal to $\frac{b-c}{a-b}$; $a-i$ being half of $a-b$, then the separation at i must be half of $b-c$, that is, half a wave length.

From the above it follows that light arriving at the point d from the strip h_1-b (Fig. 25), or the rectangle $l-l$ (Fig. 25a) at the same instant as light arriving there from the strip $i-h$, or the rectangle $i-i$, will be half a phase of vibration behind the latter, and consequently, as the intensities of both are equal, they will exactly interfere with one another and produce darkness at d . In the same way the light from the rectangle $h-h$, will exactly neutralise the light from $h-h$, also the rectangle $g-g$, will have its illuminating power on d cancelled by that of the rectangle $g-g$. Therefore d will be a point of complete darkness. The same result will be obtained if the effect at d of the spherical wave surface $a-b$, is considered, $d-b$, will still exceed $d-a$, by one whole wave length (b,c), and the conditions for complete interference at d will be found to prevail wherever we may consider the spherical wave surface $a-b$, to be situated. It is plain, from the above conditions, that the luminous focus at f cannot extend in radius quite so far as the point d . The point of maximum brightness is at f , and there is a gradual falling off of brightness before d is reached. The angular diameter of the interval f to d , subtended at the centre of the objective, is evidently equal to $\frac{b-c}{a-b}$, or to $\frac{1 \text{ wave length}}{\text{aperture}}$, for we supposed $a-b$ to be equal to the aperture, and $i-f$ to be equal to the focal length.

Therefore, in the case of an objective of square aperture ($l-n-g-m$), the exact position of the first dark space d next to the focal point is easily arrived at, its linear measurement or distance from f being equal to $\frac{\lambda F}{A}$, or the wave length multiplied by the ratio of focal length to aperture. The result is a "square" spurious disc, whose diameter lies within twice $\frac{\lambda F}{A}$.

But supposing the aperture is altered from a square form to a circular one having the same diameter, as the circle shown in Fig. 25a, then it is evident that the conditions of interference are very much modified, and the difficulty of finding exactly the first point of interference d is immensely increased. For now only a portion of the rectangular strip of wave surface $g-g$ is available for interfering with $g-g$, and only a portion

of $l-l$ for interfering with $i-i$, although $h-h$, will almost neutralise $h-h$. Therefore, at the point d , there will no longer be darkness, for there will be a balance of wave motion, due to the excess of the area of $g-i$, $g-h$, $i-h$, over the combined arc bounded areas within $l-l$ and $g-g$. To find the point d correctly therefore involves very careful analysis, but it is evident that $d-f$ must be increased.

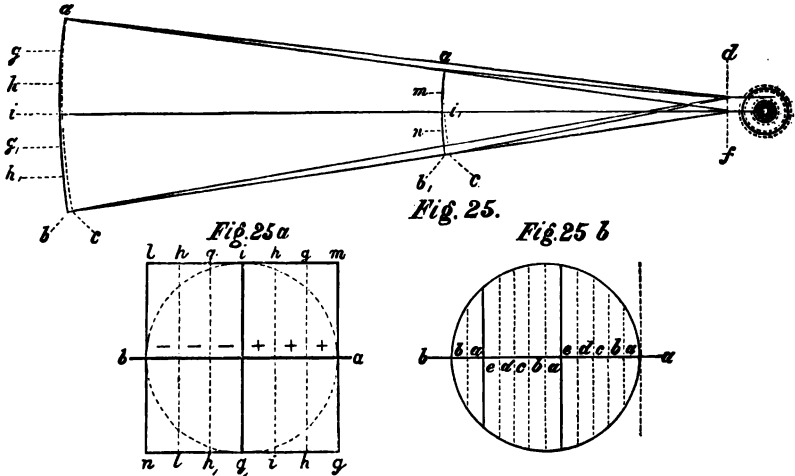

Sir George Airy, as the result of careful mathematical investigation, arrived at the result that d will be a point of perfect darkness, provided that the excess of $d-b$ over $d-a$ is equal to 1.2197 wave lengths, or about one wave length and a fifth. Thus if $a-b$ is divided into six parts, then the position of the line where the interval between the two imaginary spherical wave surfaces is equal to one wave length will fall at about h , Fig. 25, or the thick line to the left in Fig. 25b.

In the latter figure the strips lettered above the diameter are severally in opposite phases of wave motion to those lettered below the line, and the sum total of their interferences at the point d is zero. If, in Fig. 25, d is supposed to be so placed that $b-c = 1.22$ wave lengths, then, if the figure is rotated about the axis $i-f$ the point d will trace out a circle about f , which corresponds to a dark ring which embraces the spurious disc of light within it, as shown in the figure. Outside the dark ring will be a bright ring, the points along which correspond to where the light from any wave surface ($a-b$) again leaves a balance of luminosity.

The linear diameter of this first dark ring will then be equal to $\frac{2F \times 1.22 \lambda}{A}$, where F = the focal length, A the aperture, and λ the wave length.

The *angular* diameter, as viewed from the optical centre of the objective, will be equal to $\frac{2 \times 1.22 \lambda}{A}$.

In the case of an objective of 6 inches aperture and 90 inches focal length, the lineal diameter of the first dark ring will be equal to $30 \times 1.22 \lambda$, and if we take the wave length of the most luminous light (citron green) as about $\frac{1}{25800}$ inch, then this amounts to '00081 inches, or $\frac{1}{12300}$ th, while the angular diameter of the same is '000009, which is the circular measure for 1.86 seconds of arc.

Since the spurious disc is brightest in the centre, and really shades off into the dark ring, it is evident that its apparent linear extension will depend very intimately upon the brightness of the star in question, that the spurious disc formed when a bright star is viewed will appear larger than in the case of a dim one, although the maximum size can never amount to as much as the diameter of the first dark ring. To this must also be added the effect of irradiation in the case of the brighter stars. As a matter of fact, it is notorious how much smaller the star-discs appear to be in the case of small stars than in the case of bright ones. On the average perhaps, the diameter of a star disc may be considered as one-half that of the first dark ring. In all objectives having their focal lengths equal to 15 times the aperture, then the linear diameter of the spurious disc may be said to average '0004 inches or about $\frac{1}{25000}$ inch. With 6 inches aperture this corresponds to an angular diameter of 0.9 seconds, and in a 12-inch aperture to 0.45 seconds. So these respectively represent the dividing powers of such apertures upon double stars of average brightness.

From the above theory of the formation of the spurious disc and rings, it follows that the disc and rings formed by those red rays which come exactly to focus, will be larger than the disc and rings formed by the green-blue rays in the proportion of their relative wave lengths, and they will consequently not coincide, and thus the fact is accounted for that the spurious disc, if examined under favourable conditions, is seen to be edged with red and be more greenish in tint at the centre, while the first bright ring is greenish inside and red outside. And since the angular radius (in circular measure) of the first dark ring should be equal to $\frac{1.22 \lambda}{\text{aperture}}$, it should therefore vary in inverse ratio to the aperture. This is fully borne out by facts.

It is most interesting and instructive to observe the image of a bright star through a large telescope furnished with an iris diaphragm, using a high magnifying power. While the full aperture is in use, the usual spurious disc is seen, but, on working the aperture down, the disc and its rings will be seen to spread out in the most remarkable manner, until, if the

aperture is cut down to one-quarter, it will be four times as large in every way as before, moreover the coloured fringes and the general structure of the disc and rings become more evident, although less bright.

We have availed ourselves of the property of the spurious disc varying in size in inverse ratio to the aperture, to make some careful micrometer measurements of the diameter of the first dark ring when the aperture was purposely cut down, yielding a spurious disc and rings which are *much more easily and accurately measurable* than when the full aperture is in use.

A six-inch objective, of 91 inches focal length, was directed to a bright star, and the objective cut down in the first place to a *square* aperture 1.5 inches diameter. The mean of four measurements gave the diameter of the first dark ring (in this case square in shape) as .0027 inch, while the formula $\frac{2F\lambda}{A}$ (where $\lambda = \frac{1}{45800}$ inch) gives .00266 as the theoretical value.

A circular aperture, diameter 1.22 inches, was then placed in front of the objective, when the mean of four measurements gave a diameter of .0039 for the first dark ring, while the formula $\frac{2F \times 1.22 \lambda}{A}$ gives a value of .0040.

In both cases the image was viewed through an eye-piece magnifying about 450 times, and, in order to ensure having to deal with a somewhat definite wave length, a piece of green glass was placed behind the eye-piece. According to a spectroscopic examination, this glass allowed to pass with freedom only those rays lying between D and E , the maximum transparency being rather nearer to E than to D , and having a wave length of about $\frac{1}{45800}$ inch. Since this is about the brightest part of the spectrum, this wave length is a good one to take as a basis for calculating the size of the first dark ring.

The theoretical values and the actual measurements are therefore in as close an accordance as can possibly be expected, when the wave length is only an approximation. The diameter of the spurious disc itself was apparently about two-thirds of that of the first dark ring, and its outline shaded off into the latter.

The diameter of the first dark ring, as depicted with the whole aperture of six inches in use, was also measured as nearly as its minute size would allow, the measurement obtained ranging about .0008 (subject to an error of perhaps 10%), while the value given by the formula $\frac{2F \times 1.22 \lambda}{A}$ is .00081. Thus the theory accords perfectly well with the facts.

For some very interesting information concerning the beautiful interference phenomena to be seen at the focus of a telescope, when compound apertures of various shapes

are placed in front of the objective, we would refer the reader to Sir John Herschel's article on "Light," in the *Encyclopædia Metropolitana*.

It will be plainly seen that in order that an objective shall form at its focus a neat round spurious disc and rings, so well defined as to leave the observer in no doubt as to whether he has got the exact focus or not, it must be corrected for aberration with great nicety and exactness. For instance, if an objective, whose focal length is fifteen times the aperture, were so deficient in this correction as to cause the edge rays to focus at a point one-eightieth of an inch within or beyond the focus for the central rays, it can be shown that the least circle of aberration (or the smallest circle through which all the rays could pass at the focus) would be $\frac{1}{8800}$ of an inch in diameter, or equal to more than half the size of the spurious disc which ought to be formed. Doubtless then the effect would be to make the disc perceptibly larger than it ought to be (in the case of small stars at any rate), and any spherical aberration greater than this would be very detrimental to good definition, and become more serious as the relative aperture is increased.

MECHANICAL STRAINS.

All strains which distort the lenses in any way may affect the definition to a very serious extent, although, as we will presently point out, the degree of mischief done depends very intimately upon the forms of the curves and also upon the relative thicknesses of the crown and flint lenses.

Strains may be brought about in the following ways:—

1st, by pressure of the cell upon the objective, either in its own plane or at right angles to that plane.

2nd, by unevenness of temperature when the objective is cooling down or *vice versa*.

3rd, by defective annealing of the material of the lenses.

4th, by the sagging of the lenses between their points of support owing to their own weight, this occurring to a serious extent only in the larger sizes, over 6 inches aperture for instance.

(1) An objective should never be embraced tightly by the cell in the direction of its own plane, but just sufficient slackness of fit between the lenses and the cell should be allowed at ordinary temperatures as will permit of the cell just fitting the lenses (without nipping) at the lowest temperature at which the objective is likely to be used. Not only so, but it is better that the objective should only be allowed to come in contact with the cell at three equidistant points on its edge, the cell being provided with three

projections or cheeks on its inner cylindrical face. If these are fixed, then the degree of slackness of fit above mentioned should be allowed, but if the instrument is one of great precision, such as a transit instrument, it may be necessary that one of the three studs should press, by means of a yielding spring, the objective continually up against the other two, in order to prevent any lateral shifting which would disturb the accuracy of collimation. The pressure necessary to do this need not be sufficient to do any harm, moreover the moderate pressure of three equidistant points can never do as much harm as the violent pressure at *irregular* intervals round the edge, which would take place at low temperatures were the cell unprovided with studs and made too close a fit. Fig. 24 is a specimen of the sort of appearance caused by such distortion.

It is still more necessary, in objectives over 4 or 5 inches aperture, that the edge of the flint lens should not be allowed to bed itself anyhow and at random upon a single flange, but the latter should be provided with three slight projections *P, P and P*, Fig. 9, corresponding to the positions of those which confine the lens laterally. For even supposing that the flange of the cell were turned with mathematical accuracy, it would be next to impossible to make sure that the flint actually touched it all round; as a matter of fact the flint would really rest itself upon chance particles of dust, and if the particles upon which it rested happened to lie nearly at opposite ends of a diameter of the objective, it is evident that the lens would sag down on each side of such line, and there would be seen close to the focus the rough astigmatic effect shown in Fig. 24*a*. Thus there is no certainty in such a method of bedding a lens, owing to the existence of dust. Moreover, apart from dust, however true the flange may be, it is next to impossible to ensure that it will not be somewhat distorted when the cell is fixed in its place. Hence then the necessity for adopting three equidistant fixed points for the lenses to rest upon and also for confining them. Nor again should the crown lens be allowed to find its bed anyhow on the edge of the flint. There should be three projections, made of tinfoil, paper or very thin card, pasted on the edge of the flint at positions directly over the projections which support the flint. The weight of the crown is taken by these projections and transmitted direct through the flint into the three points supporting the latter. And lastly, the counter ring or upper flange, which confines the crown from above, should also be provided with three slight projections, which must lie just over the two sets of bearing points above described. This upper ring should not bear down upon the crown with more pressure than is requisite for preventing the objective turning round when

wiped or otherwise handled. It will be seen that all such pressure, being exerted at those points of the objective which are supported immediately below, can have little or no effect in distorting the lenses. They are held and supported at three equidistant points, while they are entirely free from contact with anything along the circumference lying between. But in objectives of 12 inches aperture and upwards, even the pressure of the counter ring is better avoided, and a little play perpendicular to the objective allowed, the weight of the lenses being sufficient to prevent rotation.

(2) It is of the greatest importance to know that when an objective is cooling down, as in the case of a telescope being brought out of a house into the cold night air, the best performance is not to be expected from it. A 6-inch objective should be allowed at *least* half an hour for settling down into an even temperature before the observer should expect to use the highest powers with advantage.

When an objective is in its tube and exposed to a lower temperature, it tends to cool most rapidly upon the outside of the crown, while the back of the flint cools, if anything, more rapidly than its inside surface. Thus the curvature of the first surface flattens somewhat, while the second surface is deepened, and the effect upon the flint is to cause the third surface to flatten, and the fourth surface deepen to a minute extent. The combined effect at the focus is just the same as if the objective were under-corrected for spherical aberration. The effect when inside focus will approach to Fig. 15, and outside focus to Fig. 15*a*, and may look actually worse than this on very cold nights. For a given amount of cooling, the effect increases with the size of the objective; but as large telescopes are almost invariably mounted in observatories, where internal temperature more nearly corresponds with the temperature of the outside air, the relative amount of cooling down of the objective when commencing work is not so large, and they may be put to use at once. Still it may happen that a suddenly cold night coming after a very hot day may cause a very considerable distortion in the objective at nightfall, and it may be an hour or more after opening the shutters before the image looks in good form. Besides, the effects of cooling upon the tube and its enclosed air is to cause peculiar slow flickerings of the image, and sometimes to produce a pronounced astigmatic effect, owing to the gathering of the warmer air towards the upper side of the tube.

Very often the penumbra, as seen inside focus, will show a pronounced  shape. That is it will have the shape of a capital D with its back uppermost. This is caused by a warmer stratum of air lying in the tube just behind the object glass. All these effects seem to be more noticeable in the case of tubes which are only just large enough to pass all

the light from the objective; a tube with plenty of room in it certainly tends to better images.

(3) There are very few large glass discs which do not show a more or less marked black cross when examined by polarized light, but if such cross is symmetrical and its centre coincides with the centre of the disc or lens, then the defective annealing indicated will not be likely to appreciably affect the definition, because the alteration of density or refractive power of the disc is progressive from centre to edge, and consequently the error introduced closely corresponds to spherical aberration, and may be fully neutralised by a slight modification in the figuring. If, on the other hand, the polarized light test shows a very irregular and malformed black cross, or an irregular patchy appearance, the inference is that the annealing is very irregular and defective, and likely to produce stray wings and brushes of light at and near the focus, such appearances as are shown in Fig. 12c. Defects due to bad annealing will generally show far worse while the objective is cooling down. But before a maker of repute would work up discs of any size for an astronomical objective, he would first examine them by polarized light, and if not deemed satisfactory, either reject them or have them re-annealed.

(4) There are now the important effects of the flexure of the lenses by their own weight to be considered. Almost needless to say, the flint lens is much more liable to sagging from this cause than the crown; not only is its material heavier, but its section is ill adapted for rigidity, and then there is another fact against it, which will be mentioned subsequently.

The flexure, or sagging, of each lens may be regarded from two points of view. (1) There is the flexure from edge to centre, or from centre to edge; this would be the only sort of flexure present if a lens were perfectly supported at *all* points around its edge, and its effect at the focus, if anything, is simply of the nature of spherical aberration, positive or negative. Consequently the effect of such symmetrical flexure can be neutralised by appropriate figuring, at any rate for vertical or nearly vertical positions of the telescope, when gravity acts on the lenses with nearly its full effect. (2) But the flexure which takes the form of a sagging of those parts of the edge which are unsupported, is necessarily different in its action. If the crown lens is supported upon three points as above described, then the unsupported portions between bend downwards somewhat under their own weight, while the three supported portions are bent upwards relatively, and the effect of this at the focus, *provided the flint is supposed to be perfectly free from sagging*, is to cause those rays which pass through near the unsupported parts of the edge to fall *beyond*

the true focus, while those rays which pass through at or near the supported points are caused to fall rather *short* of the true focus. Thus if the image were examined when *inside* focus, the three-cornered ring system, shown in Fig. 12*b*, would be noticed, the projecting corners corresponding to the unsupported parts of the crown. If, on the other hand, the crown is imagined to be perfectly free from sagging, while the sagging of the flint is considered, it will be seen that in its case also the unsupported parts of the edge sag downwards, while the supported parts are bent upwards, the result at the focus being that those rays which pass through at or near the unsupported parts of its edge fall *short* of the proper focus, while those rays which pass through at or near the supported points fall *beyond* the proper focus. But the supported parts of the flint lens coincide with the supported parts of the crown. Hence the effect at the focus of the sagging of the flint is *in direct opposition* to the effect arising from the sagging of the crown, and therefore, if their amounts are equal, they will neutralise one another, and there will be no effect at the focus. That is, given two discs, a certain relative thickness of the crown and flint might be hit upon, such that the flexures of the two lenses might neutralise one another. But the attainment of this condition cannot be reckoned on with confidence, since the amount of flexure in the lenses is a function of several factors, among which is the highly uncertain one of elasticity, which depends so much on the annealing. As a matter of fact, in many moderate sized objectives, 6 to 8 inches aperture, the two flexures certainly seem to completely neutralise one another, while in other cases, on a fine night, a distinctly perceptible tendency to a three-cornered effect can be made out at the focus, and on turning the lenses round it will be found that this has distinct reference to the points of support; moreover, it may be seen which flexure is the predominating one, that of the crown or that of the flint. The effect when a little out of focus is like Fig. 12*b*, and when in focus the spurious disc will show somewhat like Fig. 12*b'*, or Fig. 18. But in the case of larger apertures, a relative predominance of the flexure of one lens over that of the other, which would scarcely matter in a 6-inch objective, would very likely be enough to spoil a 12-inch or larger size for delicate double star work.

It *may* happen that the flexures may neutralise one another pretty nearly, but it is by far the best to render the objective independent of chance by introducing intermediate points of support for the edges, such points being borne up by proper counterpoises in such a manner that the weight of each lens shall be *equally* distributed among its bearing points. It is evident that the use of more than three *fixed* or rigid points would be incompatible with this necessary condition.

THE RELATION BETWEEN THE FORM OF THE CURVES AND THE OPTICAL EFFECT OF FLEXURE.

It is a well-known fact that if a prism is caused to refract a ray with the minimum deviation, then the amount of the deviation of that ray will not be appreciably altered if the prism is rotated on its base by a small amount, such as one degree.

On the other hand, if the same prism is so placed with regard to the ray as to be very considerably out of the position of minimum deviation, then one degree of rotation will cause a very perceptible alteration in the amount of the deviation. This broad fact has a very important bearing upon objectives, for it shows conclusively that if the curves can be so arranged that a ray passing through near the edge of the objective shall be refracted with minimum deviation, then ordinary amounts of flexure or distortion can have no effect in altering the amount of deviation of the ray. A prism gives minimum deviation when a ray is equally refracted at both surfaces, and so does a lens. Therefore, if the curves of a crown lens are arranged for minimum deviation for the edge ray, then the focus will not suffer from any distortions arising either from its own weight or from mechanical strains, should it be adopted for a very large objective. In order that a lens of ordinary crown shall give the minimum deviation of the edge rays, or refract them equally at both surfaces, when the incident rays are parallel, it must have the radii of its curves in about the ratio 8 to 25, the deeper curve being turned outwards to receive the parallel rays.

As an illustration, let an objective be considered whose crown lens is of the above form for minimum deviation of the edge ray. Fig. 26 represents the section of such a lens, which

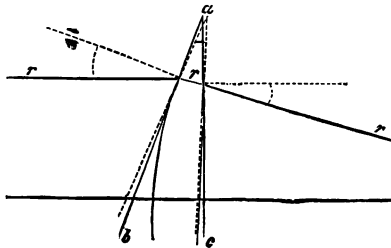

Fig. 26.

we will suppose to be a 12-inch one. If this forms part of an objective having a focal length of about 15 feet, then the focal length of the crown will be about 69 inches. The parallel ray r , falling upon the lens at a point 6 inches from the

axis, will be refracted *equally* by both surfaces, and after emergence will pass to a point on the axis about 69 inches away, a deviation of nearly 5 degrees. If two tangents be drawn, one to each curve at the point where the ray passes it, then we have the prism $b-a-c$, which is exactly equivalent to the lens in its action on the ray $r-r$. Now suppose the lens to bend towards the right at its edge, as it would do under the strain of its own weight if laid horizontally; the two tangents would then take up the position of the dotted lines, and the prism $b-a-c$ will have rotated by a small angle. Let the angle of the prism be $9^{\circ} 30'$, and the refractive index for the ray be 1.52. Then the minimum deviation would be $4^{\circ} 57' 42'' 64$. Now let the lens be bent towards the right by an amount which would cause the tangents $b-a$ and $a-c$ to rotate by 30 minutes of arc. This would represent an impossibly large amount of distortion of the lens; nevertheless, the only effect upon the ray $r-r-r$ would be to increase its deviation by *only one second of arc*.

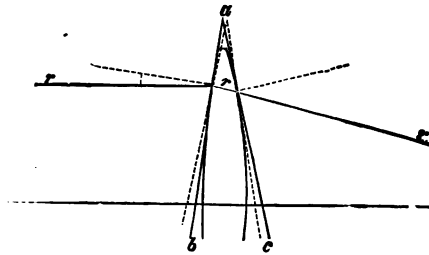

Fig. 26a.

And now let the same prism, refracting angle $9^{\circ} 30'$, be placed in the position shown in Fig. 26a, so that the angle of incidence upon the first surface is only about a third of the angle of emergence at the second surface. The prism then corresponds to a crown lens such as would be used in an objective approaching to the second type, Fig. 6, useful for its large field, the radii being as 5 to 3, or thereabouts, and the second and deeper surface exerting a refractive power on the ray, which is about three times that exerted by the first surface. If this form of lens is supposed to be bent towards the right by an amount which would cause the tangents $b-a$ and $a-c$, forming the prism $b-a-c$, to rotate by thirty minutes of arc, as in the last case, then the deviation of the ray $r-r$ will be altered by no less than eighteen seconds of arc. That is, an amount of distortion which would alter the deviation of the ray by only *one* second, in the case of a lens of least deviation (Fig. 3), would alter the deviation of the same ray by *eighteen* seconds, if it took place in a lens of the radii 5 to 3, but of the same focal length. The discrepancy would come out very

much stronger if, instead of supposing the enormous distortion expressed by thirty minutes rotation, the more likely amount of one minute had been supposed. It should here be pointed out that since the star-disc is barely *half a second* in diameter in the case of a 12-inch objective, therefore a deviation of any rays from their true path (by distortion of the objective) by any amount exceeding a quarter of a second or so, would begin to cause serious defects in the star-image.

Hence, if in the case of very large objectives the curves could be arranged so that each lens refracted the ray equally at both surfaces, there would then be no reason for fearing the ill effects of distortion, whether brought about by the great weight of the lenses, or by inequalities of temperature. It would be necessary to subject them to very forcible strains indeed before the effect would become visible at the focus. But, unfortunately, although it is easy enough to fulfil this condition in the case of the crown, it cannot be done for the flint, unless an extra dense variety is resorted to, which introduces other objections and practical difficulties. But at any rate it is of great advantage to do away with the effects of distortion, if only in the crown, for the flint is perhaps more easily counterpoised round the edges than the crown; moreover, distortions due to cooling are less serious in the flint, owing to its taking place more evenly and gradually, partly because of its shape and partly because it is not in direct contact with the outside air. Besides, when the crown is in the form for minimum deviation for the edge ray, the flint at any rate makes the nearest approach practicable to the form which would yield the minimum deviation.

But it has been pointed out before that an objective of this form, which is intermediate between those shown in Figs. 3 and 4, only yields a comparatively limited field of distinct vision. This is somewhat against it, but it must be remembered that, in the case of very large objectives, the actual field of view embraced by even the lowest powers of eye-pieces is small in relation to the size of the telescope, so that this objection need not amount to much in practice. But, since such a form of objective is very sensitive to being thrown out of square in the slightest degree, it would be advisable to make it possible to adjust it in that respect, without leaving the eye-end of the telescope. On the other hand, in proportion as objectives differ from such a type as Fig. 3, and approach to the types shown in Figs. 6 and 7, so do they become more and more susceptible at their foci to the effects of distortions and strains, however brought about, and these facts are fully borne out by practical experience. Most observers can have no idea of the difficulty there is in mounting even smaller objectives in such a manner that no distorting effects upon the surfaces can be observed when

tested by *reflection*. Luckily the refractive effect of a distortion is only about $\frac{1}{200}$ th part of the effect on a reflected ray, even in that form of crown lens which is about the worst in this respect! *

TERRESTRIAL TELESCOPES.

In the case of refracting telescopes made for viewing terrestrial objects, the quality of their objectives may of course be tested in the same manner as in the case of astronomical ones, provided that their own erecting eye-pieces are used for that purpose, for it should be pointed out that an objective must be considerably *over-corrected* for colour in order that it may appear achromatic with its erecting eye-piece. Therefore it is useless to expect good results by testing such an objective with a Huygenian or Ramsden eye-piece, or good definition on the stars if high power astronomical eye-pieces are applied to them. If the definition yielded by such a telescope, with its erecting eye-piece, seems defective, the objective can be more searchingly tested either on a real star or an artificial one. The latter is arranged by placing a bright thermometer bulb in full sunshine, and viewing the same through the telescope from a distance of not less than fifty yards. The minute image of the sun, formed virtually within the bulb, will be found to exhibit all the characters of a real star, showing a spurious disc and rings. The image of the sun in the bulb subtends at the telescope an angle very much smaller than the angular diameter of the spurious disc, at any rate unless the bulb is unusually large, or else is viewed from too near a point.

REFLECTORS.

The reflecting telescope may be tested for quality in precisely the same manner as a refractor. The same spurious disc is seen at the focus, and the same systems of rings are visible when the eye-piece is racked inside and outside of the focus. If faults in the figuring or any strains exist they will shew themselves in the same manner as in the case of the refractor.

* An alteration of 30 minutes in the perpendiculars to the surfaces of the above prism causes 18 seconds alteration in the *refracted* ray, while a *reflected* ray would be altered by 2×30 minutes, or one degree.

Thus $\frac{\text{alteration of ray by refraction}}{\text{alteration of ray by reflection}} = \frac{18}{3600} = \frac{1}{200}$ th.

THE KNIFE-EDGE METHOD OF TESTING.

We do not know to whom this method of testing is originally due, but a complete exposition of its theory and use was given by Mr. Wassall, before the Liverpool Astronomical Society, together with a partial and exaggerated statement of its superiority to any other test. As we believe there are many amateurs, especially those who construct reflecting telescopes for themselves, who seem to incline to the opinion of Mr. Wassall, we will proceed to make a comparison between the theory of the two methods and their respective advantages and disadvantages.

The theory of the direct focussing method of testing, which we have advocated in the foregoing pages, is easily understood by referring to Figs. 27 and 28, where $o-o$ represents the aperture of the objective, l a simple eye-piece, $e-e-e$ the eye, and b the focal point where a star image is supposed to be formed. The rays diverging from b are refracted through the lenses of the eye-piece and eye and come to a focus again exactly on the retina, that is provided the eye-piece is correctly focussed upon b , and that both are free from appreciable spherical aberration, which is the case with high powers though perhaps not with low ones.

Next suppose that the eye-piece l and the eye are racked inwards by the distance $b-a$. The rays from b will now enter the eye in such a state of divergence that they only come to a focus at f behind the retina, thus painting a luminous disc upon it instead of a mere point, but this is not all. The plane upon which the eye and eye-piece can focus correctly has been transferred to where it makes a cross section through the cone of rays, and it follows from the laws of optics that the disc of light on the retina is a true image and reproduction of this cross section at a , provided the eye-piece and eye are aplanatic.

On the other hand, let the eye-piece and the eye be racked outwards by the distance $a-c$. Then the plane of correct focus will be transferred to c , Fig. 28. There will be a luminous disc on the retina caused by the rays from b coming to a focus before reaching it and diverging again. At the same time it can be shown that the disc upon the retina is a correct image of the section of the cone of rays made by the plane c . But if the rays from $o-o$ focus with accuracy at b it is evident that sections taken through the cone of rays at opposite sides of b and at equal distances from it will be similar in all respects excepting coloration, absolutely similar, were the objective perfectly achromatic. Again, the luminous disc upon the retina must be of a certain size before it can appear large enough to be scrutinized in its details, and that size bears a fixed ratio to the size of the sections at a and c ,

when a given eye-piece is used ; but if the power of the eye-piece is doubled, it is evident that the ratio between the size of the disc on the retina and the diameter of the sections at a or c will be doubled, and therefore the eye and eye-piece may now focus upon a section of the cone of rays taken half-way between b and c and half the size of that at c , and yet the image upon the retina will be of the same size as it was in the first instance. That is successively higher powers enable the eye to scrutinize sections of the cone of rays taken nearer and nearer to the focal point b in inverse proportion to the powers used, and it is obvious that if the rays do not pass accurately through the focal point b , then these closer sections seen under higher powers will furnish the most distinct evidence of the fault. If there is a slight amount of spherical aberration then the section inside focus (Fig. 16) will show the luminosity growing more dense towards the edge of the section than is the case with the corresponding section taken outside focus (Fig. 16a), which latter may appear softened off towards the edge.*

* Whenever aberrations of rays from the true focus exist in an objective, it can be shown that a cross-section of the cone of rays, taken at some distance from the general focus of a star, will show variations or irregularities in its brightness (generally in the form of zones), and that the relative luminosity of the different parts of the section will vary in inverse ratio to the squares of the axial distances between the cross-section and those points where any rays cut through cross the optic axis.

For instance, if an objective has the fault of a zone, the rays from which cross the axis at a point $\cdot 01$ inch short of the main focus, and a cross-section be taken at $\cdot 2$ inches within the main focus, then the distance of the section within focus for the rays from the faulty zone will be $\cdot 19$ inches, and the brightness of the section, where it cuts through the zone, compared with the brightness of the rest, will be represented by $\frac{20^2}{19^2} = \frac{400}{361} = 1\frac{1}{3}$. Almost needless to say, such a zone, distinguished by 11% extra brightness, could not escape notice, especially when its existence would be confirmed by a corresponding zone of 10% less than the average brightness revealed by viewing a cross-section taken at $\cdot 2$ inch *beyond* the main focus. But the above formula is only true when a point of light is focussed upon, such as a star. Should the object focussed upon have any moderate size, the variations of brightness in

any cross-section of the cone of rays will be represented by $\frac{d^2}{\left(\frac{D}{r} + d\right)^2}$ where

d is the diameter of the focussed image of the object (a planetary disc, for instance), D is a variable, representing the axial distance from the cross-section to the point where any particular rays, cut through by the section, cross the axis (as instanced above), and r is the ratio of focal-length to aperture of the objective. It is evident that as d grows relatively large, so will differences of brightness in the parts of any cross-section (consequent upon the objective being defective) tend to disappear. Moreover, an additional complication will be introduced, owing to the increasing overlapping of the elementary cones of rays. But if d is only just large enough to cause the systems of interference rings to so overlap one another as to give an out of focus disc of continuous brightness, then it will be found that irregularities due to aberrations will show themselves almost as unmistakably as they would do were the telescope directed to a star and a critical examination made of the configuration of the interference rings.

In practice, however, the Huygenian or Ramsden eye-pieces used for such testing always possess a certain amount of positive spherical aberration, which varies in proportion to the square of the ratio between aperture and focal length of the objective. Supposing the objective to refract all the rays absolutely to one point, nevertheless the effect of the eye-piece is to cause an appearance of positive spherical aberration; the cross section of the cone of rays inside of the focus will appear strong round its edge, while the cross section outside of focus will appear softened off around its edge. However, with ordinary objectives, having a focal length equal to fifteen times the aperture, the spherical aberration of eye-pieces of moderately high powers is only just perceptible, and shows itself in a more marked degree with the lowest powers. Therefore, a first-class objective must have its spherical aberration very slightly over-corrected in order to suit an average high-power eye-piece.

In Fig. 29 is shown a case of very strong aberration such as would be yielded by a truly spherical mirror $o-o$ when tried on a star. The theoretical focus for the central pencil is at f , that for the edge rays at a , so that $a-f$ is the whole amount of the aberration. It follows that the least circle of confusion is at b , one-quarter of $a-f$ from a , while c , one-quarter of $a-f$ from f , is the point where the rays from a narrow zone $d-n$, half-way between the centre of the mirror and the edge, will cross the axis. If the eye and eye-piece are focussed upon a , then of course the edge rays focussing at a and forming an ill-defined bright point there, will again focus to a bright point on the retina, while the other rays through which a cuts will form a diffused halo upon the retina, since they are all diverging from successive points between a and f which are in various degrees so near to the eye that they focus at points beyond the retina. From such considerations alone it will be seen that the image on the retina must resemble the section taken through the cone of rays at a .

And now, in illustrating the knife-edge test, let it be supposed that a lower power is substituted for l , sufficiently low to enable the eye to focus upon a section of the cone of rays, either on g or h (for example), without such section appearing too large and dim. Under such circumstances the sections will appear tolerably uniform and regular in luminosity, being so far from the pseudo-focus. Or the eye-piece may be dispensed with, and the eye placed somewhere close behind f , when a disc of luminosity should be seen, apparently filling the mirror $o-o$ up to the edge. Suppose a knife-edge, with its edge perpendicular to the plane of the paper, to be advanced edgewise from right to left across the cone of rays in the plane a . Then the first rays to be stopped

will be those from about d , and the eye will see a luminous disc $A 1$ with a dark patch to the right of the centre. When the knife-edge has reached the centre exactly, the above dark patch will still remain, while the rays from the extreme edge will be simultaneously *in course* of being cut off and will have

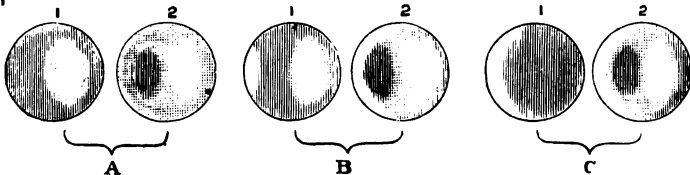
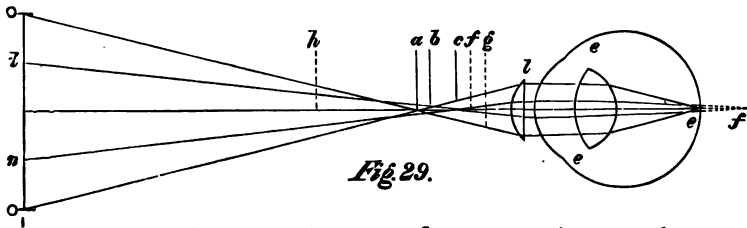
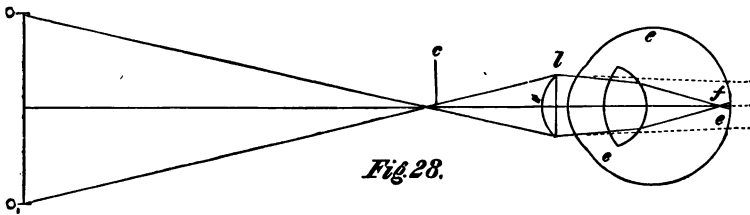
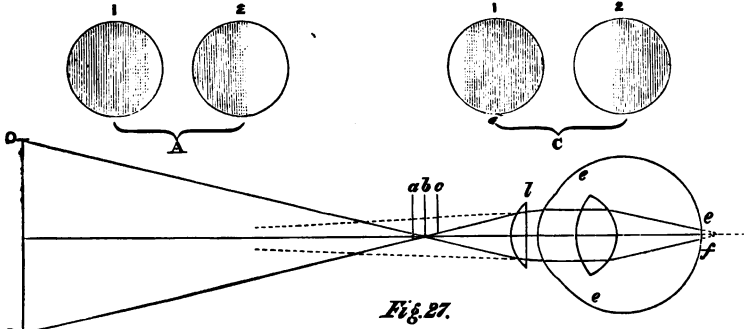

half disappeared, at the same time that the rays from about n will escape the knife-edge altogether. Therefore the disc will appear as in $A 2$. It should be borne in mind that all

these figures are in negative, the shading standing for illuminated portions.

If now the knife-edge is transferred to the plane b and made to traverse the least circle of confusion, the first rays to be stopped will be those from d and those from o simultaneously, as in B 1. On the knife just reaching the axis it will be on the point of cutting off simultaneously all the light from that zone which focusses at b , which zone will be $\frac{1}{4}$ ths of the full aperture. Rays from d will be cut off entirely, while those from n only will escape. Therefore we have a figure like B 2. If the knife-edge is transferred to the plane c , the first rays to be stopped are those from o , and the result is like C 1. On it reaching the axis, all the rays from the zone $d-n$, which focus at c , will be getting stopped off simultaneously, leaving a half dark ring, while those coming from points between o , and n , and also those from between d and the centre, will be stopped entirely, the only light yet uninterfered with being that from between n and the centre. The result is the arrangement of light and shade shown in C 2.

Turning now to Fig. 27, where all the rays are supposed to focus accurately at the point b , it will be seen at once that if the knife-edge is made to traverse the plane a , within focus, the first rays to be stopped will be from the extreme right of the aperture, and as it advances the rays which escape will always be bounded by a segment of a circle on the left, and the vertical chord of the knife-edge on the right. A 1 and A 2, Fig. 27, respectively represent the first contact, and the case of the edge having just reached the axis. But if the knife-edge is caused to traverse the plane c , *outside* focus, it is evident that the appearances will be the opposite of those seen in the former case, for the first rays to be cut off will be those from the left hand side of the aperture, and therefore the shadow will seem to advance from the left hand. Thus the observer can always say whether the knife-edge is within or beyond the focus, and by altering its position along the optic axis accordingly, he can find the position where the action of the advancing knife-edge is to cut off all the rays from the objective or the mirror *simultaneously*, as is necessarily the case, when the edge cuts exactly through the focal point b . If there is no longer the slightest tendency to cut off either the right hand or left hand margin of the luminous disc before any other part, then it is certain that the knife-edge is at the focus within a very small margin of error. There is no more exact method of finding the exact focal point than this. In the case of objectives with their focal length equal to about fifteen times the aperture, we find it possible to find the focus with no greater error than $\frac{1}{200}$ th of an inch, if the definition of the star is steady. This is one of the chief uses of the method.

There is another use to which it has been put by makers of reflectors, and that is for finding the radii of the different zones of parabolic reflectors of large aperture, when it may be inconvenient or impossible to try them by the best of all methods, that is on a star. A correctly figured reflector has a parabolic curve, the radius of each zone increasing as the edge is approached. By mounting a knife-edge and an artificial star at the centre of curvature, and receiving the light as it is reflected back into the naked eye, the mirror will be apparently filled with light, and the knife-edge may be employed for finding the foci for each successive zone, for if the light from any particular zone can be made to disappear simultaneously, it is then known that the knife-edge is traversing its focus. The differences between the foci of the successive zones should, if the figure is parabolic, come out just double the theoretical differences which should exist between the respective radii, provided the artificial star is immovable, or equal to the theoretical differences if the star moves along the axis with the knife-edge.

It is almost needless to point out that the knife-edge must be mounted in rigid attachments, and be capable of an accurate and measurable motion parallel to the optic axis by means of a fine screw. When it is at the focus, a lateral or traversing movement of $\frac{1}{1000}$ th of an inch may make all the difference between the whole light passing and all being stopped, so that a very delicate movement across the axis must be allowed for. This test has been advocated for detecting minute faults in a mirror or objective, by using it at the focus in the manner indicated in Fig. 29, the faults showing themselves in the form of the irregular appearances shown in the Figs. *A*, *B* and *C*, although perhaps in less pronounced forms.

Certainly, with care and patience and the expenditure of considerable time, the faults may be so detected, and after a good deal of thinking the visual appearances may be interpreted, but all this involves a needless loss of time and exercise of patience, while the other method, which we have advocated in these pages, is very much more direct, expeditious, easily applied, and also more searching and severe, at any rate when applied by one who has had considerable experience. The knife-edge test has its uses, but we can confidently state, after comparing both methods together, that for the purpose of detecting errors of workmanship, etc., the direct focussing method has the decided advantage in practice. When an objective seems faultless under the direct focussing test, no amount of bothering with the knife-edge will give any other result than to cause the whole disc of light to vanish simultaneously, as it should do when the rays focus accurately to a point. On the other hand, an

objective that shows a little residual fault under the direct focussing test may easily pass muster under the knife-edge test, because the objective may be absolutely free from aberration in itself, whereas there should be sufficient negative aberration to counteract the influence of the eye-piece. The knife-edge test makes no allowance for the requirements of the eye-piece. It is interesting to know that the keenest of observers, the Rev. W. H. Dawes, insisted upon there being no test for an objective so severe as the direct focussing method.

There is another "method" of testing an objective or mirror for aberration about which a few words should be said. We have heard of observers stopping down the aperture, to perhaps one-third, with a piece of cardboard with a hole in the middle; then, after getting an object into focus with a certain eye-piece, the cardboard is removed, a disc equal to the aperture in the latter is placed over the centre of the objective, thus leaving exposed the outer zone which was covered before, and then the observer notices carefully how much the eye-piece has to be racked in or out in order to get the image into correct focus. If any alteration has to be made, he forthwith concludes that either positive or negative aberration exists. Nothing could be more grossly misleading than this practice, for the simple reason that when an objective is stopped down to a small aperture near the centre, the cone of rays painting each point of the image is so narrow that the eye-piece may be racked in and out between considerable limits without the definition seeming to be disturbed, hence it is impossible to fix the focus with that confidence which would warrant the observer in concluding that the centre area had a different focus to the outer zone. The observer may easily convince himself of the futility of this procedure if he will go about it in the opposite way, first covering up the centre and finding the focus accurately for the outer zone, and then covering up the outer zone and exposing the central part before covered, look through the eye-piece and see whether the image does not still appear in focus. If it does not, and the eye-piece has to be racked in or out before *more distinct* vision is obtained, then the objective must be a shocking bad one, and under the ordinary direct focussing test, at full aperture, it ought to exhibit a dense bright patch about the centre of the luminous disc either inside or outside focus, with a corresponding vacuity on the other side of focus, and such feature ought not to escape the notice of the most casual observer.

We have emphasised the words *more distinct* just above, because, when an objective is cut down to (say) one-third of its aperture, the spurious disc which represents each point of the image is made three times as large as when the full

aperture is used, therefore the image must be expected to appear less sharp and well defined, so the observer must not conclude he can necessarily find a better focus. All really good objectives, whether telescopic or microscopic, should give the most crisp definition when the full aperture is in use, any contraction of the same being at the expense of the definition, to say nothing of the illumination of the image.

These tests with cardboard discs and diaphragms are all apt to mislead; if there is any zonal aberration at all, nature's laws, as manifested in the exquisite and complex reactions of light waves upon one another, will, to a certainty, reveal such faults in the irregular distribution and brightness of those interference rings which unfold themselves as the observer racks inside and outside of the focus.

The theory of interference of light would lead one to expect that any cone of rays, converging to a point, must be broken up into a series of unbroken and exquisitely thin conical (?) surfaces or shells of luminosity alternating with conical (?) shells of darkness, the alternate bright and dark apices of such shells all lying along the optic axis, the apices of the more interior and shorter shells of course falling successively nearer the objective. Therefore any cross section of the cone of rays must reveal a system of rings, the number visible depending upon the number of shells which are cut through by the plane on which the eye is focussed, that is, upon the distance from the focus. Now, the theory of interference would seem to indicate a separate system of shells and rings for each colour that goes to focus. The *F* rays, for instance, forming a system of shells and rings which would be closer together than the rings formed by the *C* rays in proportion to their respective wave lengths, or as 3 : 4, would lead one to expect something like a series of fine Newton's rings; but there seems to be no marked indication of such an effect in the case of ordinary double objectives, of the larger sizes at any rate. But this may doubtless be accounted for by the fact that only a limited range of the spectral colours constituting white light is refracted to anything like one and the same focus. It is significant that in the case of our Photo-Visual Objective, whose achromatism is practically perfect, the interference rings seen when at a considerable distance either inside of or more especially beyond focus, certainly show themselves fringed with colours to a much more marked degree than is the case with ordinary double objectives.

Whether the shells of light and darkness are all strictly conical right up to the objective, or whether a longitudinal section through the axis would exhibit some sort of curves, we are not in a position to state, although it is evident that the outer shell must be conical, on the whole at any rate.

For, as may be gathered from the appendix (page 75), there is the strongest possible evidence of the cone of rays tapering off into a cylindrical form as the focus is approached.

But, by way of illustrating the fineness of these rings, we may say that with a 5-inch objective we could count six interference rings when the eye-piece (a high power) was racked within focus by $\cdot 21$ inches. The ratio of the radius of the aperture to the focal length was $\frac{1}{25}$ and $\frac{1}{25}$ th of $\cdot 21 = \cdot 0076$ as the radius of the cross section of the cone of rays focussed upon, so that the average interval from centre to centre of the rings was $\frac{0.076}{8} = \cdot 0013$, or approximately $\frac{1}{800}$ th of an inch. The intervals between the more interior rings always grow successively smaller, but the quickest gradation is from the outside one to the third or fourth.

THE COOKE PHOTO-VISUAL OBJECTIVE.

This objective, although composed of three lenses, may yet be included in Class 2, before dealt with, since it is perfectly free from coma. Thus, no amount of tilting within reason will make it show any side flare, but only astigmatism of the types illustrated in the Frontispiece, Fig. 12, *d*, *d'*, and *d''*. So that the same method of squaring on as has been recommended for Class 2 might be used in this case, were it not that we have a very much simpler and better method to recommend which has the advantage of being very delicate, and yet can just as well be carried out without opening the roof of the observatory. It is a method whereby the sixth, or back surface of the objective can be made to face the eye-piece accurately and squarely by a reflection test. Of course, if the back surface is accurately squared on, then all the other

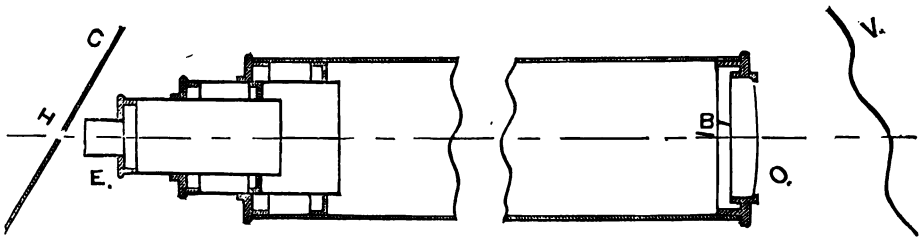

Fig. 30.

surfaces follow suit. We will explain the method by means of the accompanying diagram, Fig. 30, where O is the objective and E is the eye-end, with the eye-piece taken out.

First, a piece of dark material V such as velvet or dark brown paper is held up in front of the objective, and at some

distance in front of it. The object of this is to furnish a dull background against which the eye, placed at the eye-end, may see the aperture of the objective as a circular grey patch of light. Then a piece of white card C with a hole, H, about one-fifth inch diameter is held diagonally behind the eye-piece and in front of the eye, so that the eye may view the objective through the hole. This card must be brightly illuminated, when a reflected circular image of the eye-end aperture, showing fairly white and with a black spot in its centre corresponding to the hole, should be visible in the back surface of the objective. This image will have an apparent diameter equal generally to about one-eighth part of the apparent size of the objective. It will not be easily seen if the background V is too pale or too brightly illuminated. Now, if the objective is correctly squared on, then the bright circular image of the eye-end aperture should appear exactly in the centre of the objective. If it is not but is displaced towards the right hand, then the objective must be tilted outwards on the same side by means of the antagonist screws of the counter-cell and *vice versa*. When giving the final adjustments it is important that the observer should keep the hole in the eye-screen exactly in alignment with the axis of the tube. He can easily see whether he is right in this respect by watching the reflected image, which should show like a circular white patch enclosing a dark spot which will appear exactly in its centre if the eye-hole is upon the axis of the tube. Should one of these objectives show any coma or side flare under any circumstances, the only conclusion is that one of the separate lenses has got slightly misplaced by a shock or something of that sort, and the observer should preferably return it to us for re-adjustment, since no amount of tilting the objective *as a whole* would ever cure it. It would indicate that one of the component lenses had got slightly out of square with respect to the other two. The lenses composing this objective require more perfect centering and more careful adjustment than those of ordinary double objectives, and therefore we recommend even more careful handling if possible. It is so important that the lenses shall be allowed no side play whatever, that we have adopted a form of cell in which the lenses are confined by a perfect fit at all temperatures, but without nipping, by means of a simple and reliable zinc and brass compensation, which has been tested carefully between the range of 20° to 120° Fahrenheit with no difference of fit manifesting itself. Compensated cells are used for all sizes of 4 inches aperture and upwards, while in sizes below 4 inches aperture a spring is introduced which always gently presses the three lenses up home against two out of three equidistant cylindrical cheeks. The flint lens of this objective

is so shaped that flexure, supposing it to exist, can have scarcely any optical effect, moreover, the borosilicate flint is the hardest glass with which we are acquainted, and therefore very rigid. The two positive lenses are turned opposite ways, and therefore any flexure due to their weight results in contrary optical effects in the two cases. But here again the substantial central thickness of these lenses adds very much to their rigidity. Of course, the same optical tests of performance as have been recommended for ordinary objectives may just as appropriately be applied to our Photo-Visual Objectives, although the nature of the colour corrections is quite altered. In the ordinary objectives the observer looks for a ring-system, when inside or outside of focus, of a greenish yellow colour fringed with red inside focus, while outside focus he expects to see a bright blue flare and a bright red point superimposed upon it. But in the case of the Photo-Visual O.G. the system of rings will be found generally of a pearly white colour on both sides of focus, while the closest scrutiny will fail to show either the red spot and blue flare outside focus, or the purple and blue fringes of colour surrounding bright objects which he had almost learned to look upon as necessary evils in the case of ordinary double objectives. It will be found that under high powers the definition of fine lunar details, etc., will show a clearer and more black and white appearance than when viewed through ordinary objectives, while coloured details are rendered with that fidelity well known to be one of the great merits of the reflecting telescope.

Since the blue and violet rays are refracted to the same focus as the most luminous rays, of course a perfect photograph can always be taken by exposing the plate in the visual focus, and it will be found that a circular plate of at least the same size as the object glass will be very well covered, any stars imprinted at the extreme margin showing but slight diffusion and astigmatism. With the usual focal length of eighteen times the aperture given to these objectives, this corresponds to a circular field of at least $3^{\circ} 10'$ diameter.

But it is of little use photographing planets, excepting in the case of a very large instrument, without first enlarging the primary image several diameters, by means of a Barlow lens of some sort, for the direct image is so small and fine that its details are inevitably obliterated by the relatively coarse grain of the sensitive plate.

We have before pointed out that when ordinary objectives are in a condition of cooling down, the image always shows more or less under-corrected for spherical aberration, the edge rays falling to the shortest focus.

The same transitory fault, but existing happily in a less noticeable degree, will be found in the case of the Photo-Visual Objective, and should accordingly be allowed for.

For observations upon faint objects, where light is of the greatest importance, we would strongly recommend our single achromatic eye-pieces. These are also specially adapted for transit instruments, or for use with micrometers. Consisting only of a single cemented combination, there are two less surfaces to reflect back light, which makes up for the two extra surfaces in the objective. (This represents a gain of about eight per cent. in the light.) The field is rather smaller than that given by a Ramsden eye-piece, but is very flat and free from linear distortion, while the lens is placed at the safe distance of its own focal length behind the delicate spider lines. As, however, Huygenian eye-pieces are generally used with the Photo-Visual Objective, we generally make a practice, unless otherwise required, of so adjusting the colour correction of the objective as to yield a perfectly achromatic image when a Huygenian eye-piece, magnifying about fifty times the aperture, is in use. This would represent a power of 300 upon a 6" O.G. With lower powers than these the objective necessarily appears a trace under-corrected owing to the greater influence of the eye-piece, while with still higher powers the same objective appears a mere trace over-corrected, as it really is. And if a single achromatic eye-piece is used with the same objective, it necessarily follows that the over-correction for colour asserts itself still more, as such an eye-piece in itself exerts no positive colour aberration, like the Huygenian or Ramsden constructions. Nevertheless, these slight variations in colour correction, dependent upon the type and the powers of the eye-pieces in use, are too slight to appreciably impair the clearness of vision, and would escape all but an experienced eye, and thus may be regarded as of little importance compared to an appreciable gain in brightness in the case of faint objects.

GENERAL TREATMENT OF OBJECTIVES.

In conclusion, we will make a few remarks upon the care of objectives in general. In a dry, pure air all objectives will keep clean and beyond the need of internal wiping for a considerable period, many years in many cases. All that is necessary is to keep the outer surface clean by occasional dusting with a fine brush, followed by a careful wiping with a wash-leather or soft cambric, which must be free from all traces of greasiness. Finger marks must on no account be allowed to remain upon the surfaces, or curious cometary

appendages to stars will often result. The visibility of exceedingly minute stars depends very essentially upon the perfect cleanliness and freedom from greasiness of the surfaces. But in more humid climates the interior surfaces will occasionally require thoroughly cleaning. Many glasses have the curious property of condensing a fine film of moisture upon their surfaces when the air is humid; they are more or less hygroscopic. Ordinary crown glass, such as is almost universally used for the positive lenses of double objectives, has a perceptible tendency in this direction, while the flint glasses, generally used for the negative lens, show no such tendency. It is curious that flint glasses are very much more easily cleaned than crown glasses; the dirt seems to cling to the latter in many cases, when a preliminary wipe with pure alcohol is strongly recommended. We have often had ordinary objectives sent to us to be examined and cleaned which have been many years either in use or perhaps standing idle without internal cleaning, and which have shown an extraordinary network of fine white threads all over one of the internal surfaces. On taking the lenses apart we have always found that this fine network was upon the crown lens, and consisted of a minute thread like fungus which had more or less invaded the whole surface and nourished itself mostly upon a fine film of sweat or moisture which can be distinctly recognised upon the surface, and also upon salts rendered available by a slight decomposition of the surface of the glass. For when this fungus has been long established, it is impossible to wipe off all traces of it, it leaves behind it a decided deterioration or etching of the surface closely following the threads of the fungus. At the same time the closest examination of the flint lens fails to show any trace either of moisture or of fungoid growth. All that can be noticed upon the flint is a film of tarnish. Recognising then the indirect mischievous effect of damp when allowed to accumulate on the interior surfaces, is it not better to resort to prevention rather than cure? We are afraid that the general practice is to leave objectives to take care of themselves. For those, however, who are disposed to take a little trouble to keep their objectives dry, we would recommend the simple device which has been so often applied to reflecting telescopes for absorbing the film of dew deposited upon their mirrors after use on damp nights. While using the instrument a thick circular pad of many thicknesses of flannel was kept toasting before a fire, and on the cessation of observations this bone-dry pad was laid on the top of the mirror and the cover of the tube put on. It quickly absorbed all traces of moisture, and exactly the same policy might be adopted with refractors, only in this case the flannel pad should be introduced into the dew cap

and then the cover put on. It cannot be too well remembered that where there is no moisture there is generally no chemical re-action, and the presence of a film of moisture is not only likely to interfere with the perfect and regular refraction of the figured surfaces, but also to promote and foster fungoid growth and consequent decomposition of the surfaces. Not only will a thoroughly toasted flannel pad keep dry the front of the objective, but it will inevitably dry the interior surfaces, provided the pad is used fairly often; for the air contained inside the cell and between the lenses is continuously but slowly interchanging with the outer air by means of diffusion, also more quickly by means of the alternate expansions and contractions following upon every change of temperature. Therefore, if the air outside an object glass is kept dry, then the air inside the object glass will sooner or later partake of the same dryness. And we would recommend precisely the same treatment of our Photo-Visual Objective, the back lens of which closely resembles ordinary crown glass in all its properties. In the case where an objective is not likely to be used for a long period, by far the best way is to take it out of the telescope tube and place it in a round tin box just large enough to hold it. This box should have a closely fitting lid, and if a thoroughly dried flannel pad is put in on top of the objective, so much the better.

As regards the tarnish which we have above alluded to as being noticeable upon the flint lens of an ordinary objective after a few years of use, we are very glad to be able to reassure the owner of such a flint that this film of tarnish, generally looked upon with suspicion, is really a very good friend to the observer, inasmuch as it increases the transparency of his objective. We have seen so many proofs, some quite unsought and some the result of intentional experiments, of the unmistakably increased transparency of tarnished surfaces as compared with freshly polished surfaces as to remove all doubts on this point, so that we can confidently assure observers that whereas a thin plate of dense flint glass of the type usually used for objectives will, when freshly polished, reflect back from its two surfaces about 11 per cent. of the light falling upon it, and transmit 89 per cent., the same plate, when tarnished to a sort of dull grey brown or blue (as viewed by reflection), will reflect back only about 5 per cent., and transmit 95 per cent., a perceptible gain of 5 to 6 per cent. in transparency.

If, however, the decomposition of a surface took the form, not of a transparent film of tarnish, but of a dull milky film, visible by scattered light, then of course the effect would be entirely different, and would utterly spoil the lens. But we have never yet come across a case of milky decomposition of

any glasses that have come under our direct inspection, although we have heard of it taking place with certain phosphate glasses in tropical countries.

In conclusion, should any of our Photo-Visual Objectives show unmistakable signs of requiring cleaning on any internal surfaces, we would strongly recommend the owner to forward the objective to us, since taking them apart and putting them together again is not quite such a simple operation as in the case of ordinary objectives, and requires considerable care and experience.





Reprinted from the MONTHLY NOTICES OF THE ROYAL ASTRONOMICAL SOCIETY,
Vol. LIV., No. 2.

THE SECONDARY COLOUR
ABERRATIONS
OF THE
REFRACTING TELESCOPE IN
RELATION TO VISION.

BY

H. DENNIS TAYLOR.

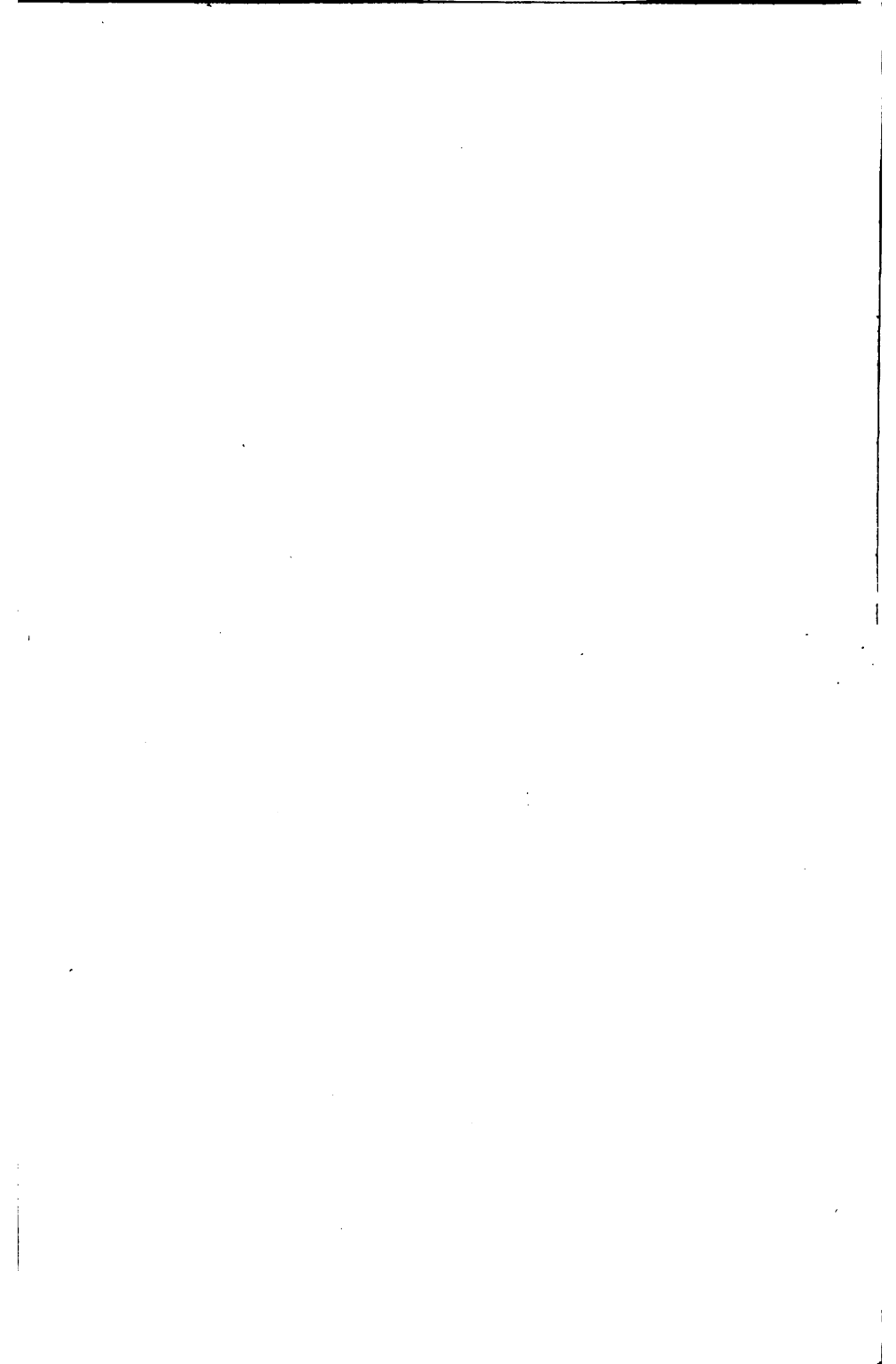

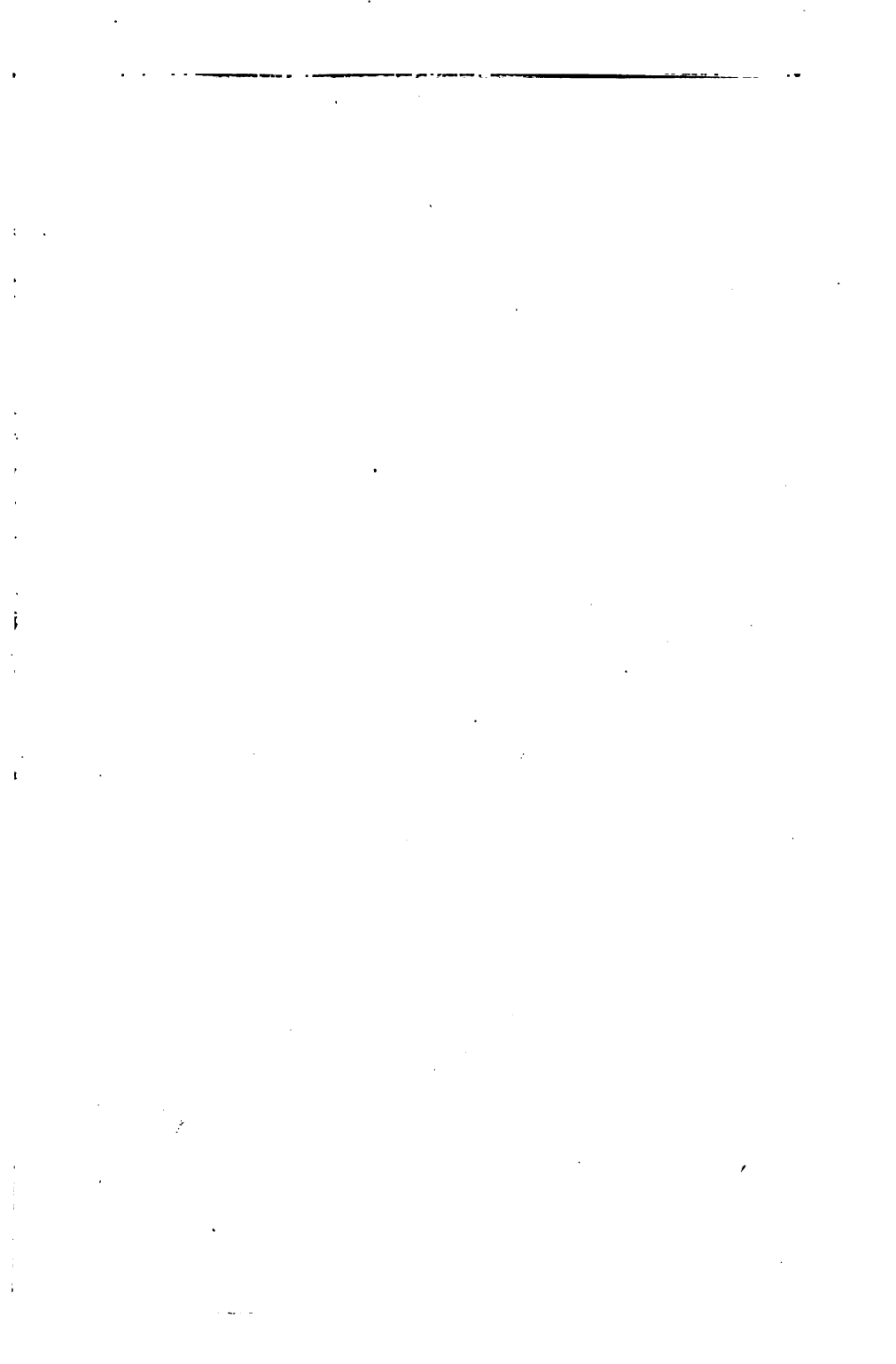

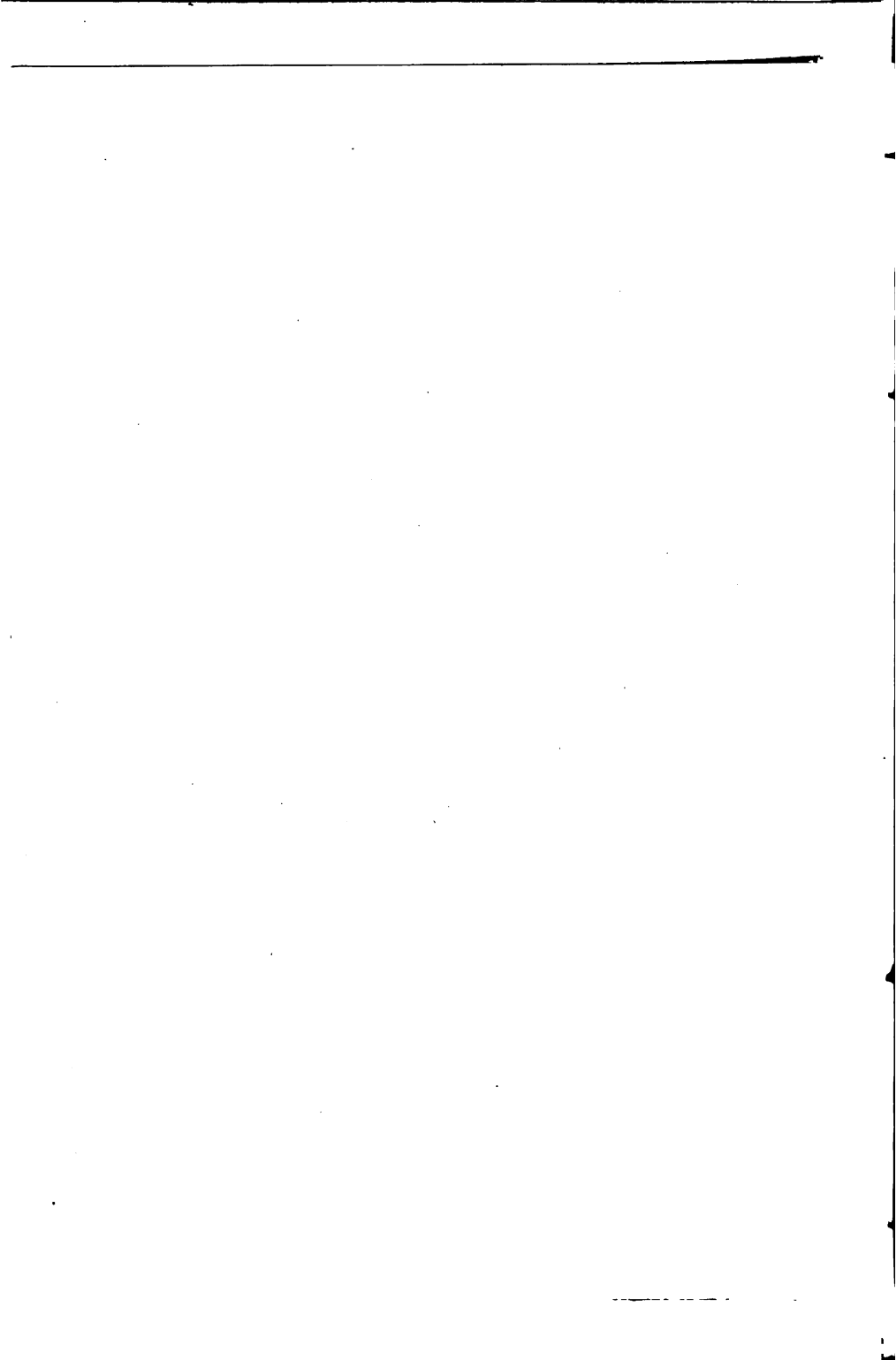

THE SECONDARY COLOUR ABERRATIONS OF THE REFRACTING TELESCOPE IN RELATION TO VISION.

IT is notoriously easy to grow so accustomed to a supposed necessary evil as to become practically oblivious of its presence. The astronomer who diligently uses his refracting telescope ceases to notice the ever-present halo of purplish light which surrounds the objects of his scrutiny, and is somewhat startled, or even offended, when some brother astronomer, accustomed to use his reflecting telescope, takes a look through the refractor, perhaps for the first time, at a planet or a star, and recoils with an expression of surprise at the unsightly amount of coloured fringe which he sees. And, certainly, to one who sees it for the first time and has always heard the refractor spoken of as *achromatic*, the secondary spectrum seems far too aggressive a fault to be ignored.

Much has already been written about the secondary spectrum of the refracting telescope, but, I venture to think, to relatively little practical purpose.

The theory of vision through the refractor has, so far as I know, never yet received adequate attention. At the same time, the production of an objective practically as achromatic as the reflector has in many quarters been looked upon as a mere refinement, because the very serious nature of the secondary colour aberrations of ordinary objectives, especially when their apertures are measured by feet, has not been sufficiently realised. I will now proceed to give what seems to me sufficient evidence of the detriment and loss of utility suffered by the larger refractors owing to the imperfect nature of their achromatic corrections.

Plate 1 illustrates the secondary colour aberrations of the refracting telescope in the form of graphic curves.

First of all, in Fig. 1, is shown the colour curve of the great Lick refractor as plotted out from the actual measurements of the foci for the various colours, executed with great care by Mr. James Keeler by means of a large spectroscope.*

The great objective is so corrected that the two rays, B and F, come to exactly the same focus, which is taken as the zero

* *Publications of the Astronomical Society of the Pacific*, Nov. 9, 1890.

in the following table, where the colour aberrations are preceded by a + sign when the respective colours focus beyond the focus for B and F, and by a — sign when they focus short.

TABLE I.
Lick Refractor. Focal Length = 57 feet.

Wave length.	Fraunhofer line.	Distance of foci from focus for B and F. Inches.
·6867	B	0·00
·6562	C	—0·24
·5889	D	—0·45
About ·5650	Minimum focus	—0·47
·4861	F	0·00
·4341	G' or H γ	+1·45
·4101	h	+2·76
	Visual focus	—0·20

In Fig. 1, as in all the other colour curves which I give, the wave lengths are set off in arithmetical order along the perpendicular on the left hand; that is, the wave lengths (expressed in thousandths of a millimetre) are measured by the ordinates. A scale, divided to inches and tenths, is set off along the base-line; that is, the variations in focal length for the rays of various wave lengths are measured by the abscissæ.

Now, it seems to be a fact that large refractors are rather over-corrected compared to smaller ones. Otherwise they would show an aggressive amount of secondary red. We want a colour-curve more truly representative of medium-sized refractors of average colour correction. Smaller objectives are generally calculated to refract the rays C and F to the same focus, but in practice I have good reasons for believing that the average state of correction may be said to be one in which the ray half-way between B and C is united with F. The best state of correction is largely a matter of taste or individual eyesight; nevertheless, I have assumed the latter state of correction as the best to form the basis of a series of calculations, whereby the colour-curve shown in Fig. 2 has been arrived at. The Lick measurements are too few and too far apart to enable one to draw in the colour-curve with a sufficient degree of reliability from one end of the spectrum to the other. Therefore I calculated out the colour curve (Fig. 2) for a 2-foot object-glass of 30 feet focal length. The data on which I have proceeded are as follows:—

1. The very careful series of measurements of Refractive Indices for Ordinary Crown Glass and Ordinary Dense Flint Glass, executed by Dr. Hopkinson, and published in the *Proceedings of the Royal Society*, 1877 ("Refractive Indices of Glass"). These are perhaps the most accurate and reliable measurements of this sort ever executed.

2. It is well known that the refractive index for any ray of known wave length can be expressed in terms of that wave length with reasonable accuracy by means of Cauchy's formula—

$$\mu = a + b \frac{I}{\lambda^2} + c \frac{I}{\lambda^4} + d \frac{I}{\lambda^6} \text{ etc.},$$

where μ = the refractive index, λ = the wave length, and $a, b, c,$ and $d,$ etc., are constants depending upon the physical properties of the particular glass in question. As Dr. Hopkinson points out, if we wish to calculate μ from λ with as great a degree of accuracy as may be obtained by actual observation, then it is necessary to work by the formula extended to four terms, as shown above. This I have done—first working out the values of $a, b, c,$ and d for crown glass and flint glass respectively from the observed refractive indices for the four spectral lines as follows:—

TABLE II.

Ray.	Wave length λ .	Ray.	Wave length λ .
B	·6867	F	·4861
D ₂	·5889	H ₁	·3968

Next, I calculated the necessary values of $\frac{I}{\rho_1}$ for the crown lens and $\frac{I}{\rho_2}$ for the flint lens, which are necessary for refracting the ray half-way between B and C (wave length = ·6715) to the same focus as the ray F ($\lambda = \cdot4861$) at a focal distance of 30 feet. Here, as usual, $\frac{I}{\rho_1}$ stands for the sum of the reciprocals of the radii of the crown lens, and $\frac{I}{\rho_2}$ for the sum of the reciprocals of the radii of the flint lens. Then, if F represents the principal focal length of the combination, we have

$$\frac{I}{F} = \frac{\mu_1 - 1}{\rho_1} - \frac{\mu_2 - 1}{\rho_2}$$

$$= \frac{a_1 - 1 + b_1 \frac{I}{\lambda^2} + c_1 \frac{I}{\lambda^4} + d_1 \frac{I}{\lambda^6}}{\rho_1} - \frac{a_2 - 1 + b_2 \frac{I}{\lambda^2} + c_2 \frac{I}{\lambda^4} + d_2 \frac{I}{\lambda^6}}{\rho_2}$$

Let

$$A = \frac{a_1 - 1}{\rho_1} - \frac{a_2 - 1}{\rho_2}; \quad B = \frac{b_1}{\rho_1} - \frac{b_2}{\rho_2}$$

$$C = \frac{c_1}{\rho_1} - \frac{c_2}{\rho_2}; \quad \text{and } D = \frac{d_1}{\rho_1} - \frac{d_2}{\rho_2}$$

Then

$$\frac{I}{F} = A + B \frac{I}{\lambda^2} + C \frac{I}{\lambda^4} + D \frac{I}{\lambda^6} \dots \dots \dots (2)$$

or

$$A + B\lambda^{-2} + C\lambda^{-4} + D\lambda^{-6},$$

which is the formula expressing the reciprocal of the focal length for any ray in terms of the wave length of that ray.

Differentiating (2) with respect to λ , it will be found that

$$d\left(\frac{1}{F}\right) = -2\lambda^{-3}(B + 2C\lambda^{-2} + 3D\lambda^{-4})d\lambda \dots \dots (3)$$

On equating $(B + 2C\lambda^{-2} + 3D\lambda^{-4})$ to 0, it will be found that

$$\lambda^{-2} \text{ or } \frac{1}{\lambda^2} = \frac{-\sqrt{C^2 - 3BD} - C}{3D} \dots \dots (4)$$

That is, the ray whose wave length will satisfy equation (4) will be refracted to the minimum focal length. (The sign of the root in (4) has been assessed from actual trial.*)

I will here give Dr. Hopkinson's Refractive Indices for the Crown and Flint glasses respectively for the four selected rays or Fraunhofer lines:—

TABLE III.

Ray.	Crown.	Flint.
B	1.513624	1.615704
D ₂	1.517116	1.622411
F	1.523145	1.634748
H ₁	1.532789	1.656229

From these the following constants were obtained:—

TABLE IV.

Constant.	Crown.	Constant.	Flint.
a ₁	= +1.5031566	a ₂	= +1.5973804
b ₁	= +.0053061	b ₂	+ .0086972
c ₁	= -.00021147	c ₂	- .000084923
d ₁	= +.00001742	d ₂	+ .000027465

For a focal length of 360 inches for the F ray, it will be found that

$$\frac{1}{\rho_1} = \frac{1}{74.4292} \text{ and } \frac{1}{\rho_2} = \frac{1}{149.318}$$

on the supposition that the ray half way between B and C ($\lambda = .6715$) is refracted to the same focus as F.

* It is interesting to note that the use of Cauchy's dispersion formula carried to four terms (as above) only gives rise to errors in the value of μ not exceeding and generally less than .000010; which error, in the case of the crown lens, would give rise to an error of only .018 inch in a focal length of 360 inches, and an error of .009 inch for the same error in μ in the case of the flint lens. An error of .000010 in observing μ from a crown prism of 60° angle would imply an error in reading with the spectrometer equal to about three seconds of arc only. Therefore the errors likely to arise from the above application of Cauchy's formula are no greater than the errors likely to arise in taking observations of μ with the greatest care by means of the best of spectrometers.

From these data the objective constants, A, B, C, and D—see equation (2)—are found to be as follows:—

TABLE V.

A	= +.00275948
B	= +.000013045
C	= -.0000022725
D	= +.000000050085

From the above data the colour curve shown in Fig. 2 was derived. The focal lengths of the rays of the spectrum A, B, C, D₂, E, *b*, F, G, *h*, and H₁, as well as six other rays of intermediate wave lengths (where spaces seemed to require it), were calculated and gave the abscissæ of the curve. It will be noticed that its character is much the same as the actually measured curve of the Lick refractor, if we allow for the great difference of focal length. Some years ago Professor Piazzzi Smyth was good enough to send to Messrs. Cooke a series of measurements of the focal lengths of rays of various colours executed with his great spectroscope, which consisted of a large defraction grating, a collimating telescope of 4-in. aperture and 36-in. focal length, and an observing telescope of 4-in. aperture and 68-in. focal length. Allowing for there being two objectives in use, one being nearly twice as powerful as the other, and the nature of the colour correction, which brought the D and the G rays to the same focus, the colour aberrations as measured by him (if we allow for the difficulty of attaining great exactness) were found to be on a scale proportionate to the focal powers concerned. The colour aberrations of the 27-in. Vienna telescope have also been measured by Professor Vogel and found to be substantially of the same character as those of the Lick refractor, only less in amount in proportion to the smaller focal length. So far, then, calculation and actual observation are substantially in agreement.

We have now to consider an aspect of the question which is of very great practical importance, and also extremely interesting. Large refractors are looked upon as valuable because (1) of their supposed great light-grasping or space-penetrating power, and (2) because of their greater separating or dividing power, which enables them to deal easily with very difficult double, binary, and multiple star systems which are totally inaccessible to smaller instruments. Their greater separating or dividing power upon close double stars, etc., is of course fully proved, and is well known to increase directly as the aperture; it is chiefly the light-grasping power of refractors with which I intend to deal.

First of all, I will point out what seems to me to be a most inexplicable fact (?). It has been asserted with regard

to the Lick refractor (in Table I.) that the eye does *not* select a focus at that point of the optic axis where the greatest concentration of light occurs, viz., at the *minimum* focus. That the eye is able to select any distinct focus whatever out of all the innumerable various coloured foci which are continuously distributed over several inches of length in the case of very large refractors is in itself a surprising fact. But there is found to be no ambiguity in practice about the exact whereabouts of the *visual* focus of large refractors. It is asserted by Mr. Keeler that the eye places the visual focal plane at a distance of .27 inch, or about a quarter of an inch *behind* the position of minimum focus.

In Fig. 1, f_1 -- f_1 is the visual focal plane as placed by Mr. Keeler. It is seen to cut the colour curve in two places—in the red near C, and in the bluish green between E and F. These two colours, being about complementary, together would form an apparently *white* focus. In fact the quality of whiteness and not luminosity would seem to be the eye's main requirement, if this visual focal plane is rightly placed. Now, when an optician designs an object glass for visual purposes, he reasons thus: This objective has to yield an image which shall appeal as much as possible to our sense of vision; therefore it is of the utmost importance that those rays of the spectrum which exert the greatest effect upon vision should be refracted to the most compact focus possible; which amounts to this, that the visually most active rays must be refracted to the *minimum* focal length, so that the brightest part of the diagrammatic colour curve may be embraced tangentially by the focal plane.* He pursues this sound line of reasoning, embodies it in practice, and gets the brightest yellow-green rays condensed to the most compact focus. And then (if Mr. Keeler's estimate of the position of the visual focal plane is the true one), when he comes to actually use the telescope, his eye most persistently ignores the very focus which has been specially designed to suit it, and selects a focus of its own, *far inferior in brightness*, at quite a different position on the axis.

This seems the very height of illogical perversity. As an example of discordance between design and use it compares very well with the well-known case of the planter who supplied his black labourers with wheelbarrows to lighten their toil, and found them next day carrying them fully loaded, *on their heads!*

Professor Harkness, in an article on the Secondary Spectrum in the "Amer. Journal of Science and Arts," 1879, September, puts forward the following ingenious method of

* Of course the focal plane is here supposed to have a substantial thickness, as will be explained further on.

finding the position of the visual focal plane when the amount and character of the secondary spectrum are known.

In Fig. 9 is shown the same colour curve as that of Fig 2 (for a 30-foot refractor). Across this colour curve there are drawn horizontally, so as to be bisected by the colour curve, a series of short lines whose length is made proportional to the visual brightness of the light at each point of the colour scale. After the ends of these lines have been connected we have the boomerang-shaped figure shown in Fig. 9. (The figure as drawn does not pretend to any accuracy.) Let this diagram be drawn on stiff paper and then cut out and balanced upon a knife edge (which, of course, must correspond to an ordinate). Professor Harkness maintains that the position of the knife-edge necessary for a balance should indicate the position of the visual focal plane.

Now, however applicable this solution of the problem may be in the case of small objectives where the secondary colour aberrations are not too great to be embraced between the limits of the focal plane, yet it is wholly inapplicable to the case of large objectives. For the image of a star is a spurious disc, of a well-ascertained diameter, and what we are really concerned with is the quantity or luminous value of the light which actually goes to the formation of that star disc. For, as I shall presently show, the light of certain other vagabond colours focusses at points so far beyond (if not short of) the visual focal plane as to form penumbra or circles of aberration on the latter, which are so very much larger than the star disc that the light forming these said penumbra is diluted tens of times, hundreds of times, and even thousands of times, according to the colour. Therefore, such light certainly does not sensibly contribute to the brightness of the star disc, and Professor Harkness's method is no longer applicable, unless applied only to that brightest part of the curve which can be comprised between the limits of the focal layer; a term which I shall now proceed to explain.

It is of the very greatest importance in this enquiry to know what are the limits between which the image of a point of light or a star may be said to be approximately *in focus* in the case of well-figured objectives. Fig. 5 embodies the generally, and I believe universally, accepted idea of the longitudinal section of the cone of rays from an objective or mirror converging to form a spurious disc at D, and then diverging again in a similar manner on the other side. It is supposed as a deduction from geometrical optics that the figure is that of two similar cones on a common axis, with their points overlapping by a distance equal to $2 \frac{F}{A}$ times the diameter D of the spurious disc. Here F represents the focal length, and A the aperture of the O.G. In Fig. 5 I have

represented the average case of the focal length being fifteen times the aperture. Let it be supposed that the star disc is viewed through an eye-piece powerful enough to magnify the spurious disc to a very appreciable size, as in the case of ordinary double-star work. Then, if Fig. 5 is true to fact, it is evident that if the eye-piece is pushed within or beyond focus by an amount equal to the diameter of the spurious disc multiplied by $\frac{F}{A}$, or shortly $D \frac{F}{A}$, then it will focus upon a section of the cone of rays whose diameter d is equal to $2D$, and if pushed in or out by the amount $2 D \frac{F}{A}$, then it will focus upon a section of the cone of rays where $d = 3D$, and so on.

Now, in the case of any objective where $\frac{F}{A} = 15$, it is well known that the spurious disc is about '0004 inch in diameter (or rather less). Therefore, according to Fig. 5, if the eye-piece were pushed in or out of focus by a distance equal to '0004 \times 15, or '006 inch, then the appearance should be a penumbra of light equal in diameter to *twice* that of the spurious disc. Now it happened to occur to me that I would determine the limits of good focus not only theoretically, by application of the usually accepted rule, but I would also confirm it by experiment. What, then, was my surprise when I found that, so far from there being any agreement between the tacitly accepted theory and actual fact, I actually had to push in the eye-piece or draw it out in order to expand the spurious disc into a penumbra of twice its size (see Fig. 5a and b), by an amount equal to '03 inch on *each* side of focus, or *five* times as much as I had theoretically expected, while I could push the eye-piece in or out by '015, or nearly '02 inch, without sensibly increasing the size or destroying the character of the spurious disc. This astonished me, and led me to make a series of experiments with different eye-pieces, apertures and focal lengths, and varying relations between apertures and focal lengths. The results turned out to be independent of the focal lengths of the objective and the power of the eye-piece, provided the magnifying power was sufficient to show the star disc. Focal lengths of 9 inches (in which case the secondary spectrum is practically nothing) up to 11 feet were tried, with the results shown in Table VI. The first column gives the relation $\frac{F}{A}$; the second gives the whole distance of travel of the eye-piece between the point where $d = 2D$ on one side of focus and the point where $d = 2D$ on the opposite side of focus. Of course D increases as $\frac{F}{A}$,

and theoretically the taper or angle of the cone of rays also varies inversely as $\frac{F}{A}$, so the *theoretical* distances of travel, including that on both sides of focus (for producing the condition $d=2D$) given in the third column, are calculated as varying as $\left(\frac{F}{A}\right)^2$. The fourth column gives the ratio of actual to theoretical distances.

TABLE VI.

F. A.	Actual.	Theoretical.	Ratios.
8.4	.02 less	.004	5+
15	.06	.012	5
30	.18	.048	3.75
60	.54 about	.192	2.8

These measurements do not admit of great accuracy; but so far as they go they clearly prove that the taper of the cone of rays becomes much more gradual as the focus is approached, or as the diameter of the cone grows small in comparison with the wave length.

Any observer can verify these results for himself on his own telescope. The discrepancy between calculation and fact is far too great to be explained away, and the conclusion is that Fig. 6 pretty accurately represents the longitudinal section of the cone of rays near the focus when $\frac{F}{A} = 15$.

Figs. 7a and 7b show the differences between the theoretical and actual cones for a *large* relative aperture. I can scarcely suppose that I am the only observer who has noted this curious law, but I am not aware that the modification of the taper of a cone of rays near its focal point has ever been studied as a deduction from the undulatory theory of light.* But here we have a fact which renders possible what before seemed impossible, viz., the production of a tolerably definite focus out of the confusion of many foci; for since the bundle of rays is nearly cylindrical for a distance of nearly .02 on each side of focus (when $\frac{F}{A} = 15$), evidently colour aberrations to that amount on each side of focus will not give rise to

* It can be shown that no amount of residual spherical aberration can possibly account for this apparent drawing out of the cone of rays. In order to guard myself from being misled by the well-known variability of the focus of the eye of an observer, I made use of very high power eye-pieces for the greater number of the above experiments. The most powerful eye-piece used had an equivalent focal length of .15 inch, and in this case the utmost error in reading that could arise from the extremes of focal adjustment likely to take place involuntarily in my eye would not amount to more than $\frac{1}{300}$ th of an inch. For the reasons indicated above, the use of eye-pieces of equivalent focal lengths greater than about $\frac{1}{4}$ -inch would be likely to give rise to very large absolute errors in the readings.

loss of light owing to any part of it falling outside the limits of the star disc. In all the colour curves shown in Figs. 1, 2, 3, and 4 I have drawn what I call the focal layer, $f-f$, of a width in accordance with the above experiments. The focal *plane* may be indicated by a line drawn down the centre of the focal layer, while the outer dotted lines mark the limits of the focal layer. Supposing an eye-piece is focussed upon the focal plane, then the two rays of other wave length which focus respectively upon the inner limit and the outer limit of the focal layer will produce upon the focal plane two penumbra of light whose diameters are equal to twice the diameter of the focussed disc (see Figs. 5a and 5b); that is, about one-quarter* of the light which focusses upon the two limits of the focal layer will fall within, and contribute to, the brightness of the spurious disc. Any light focussing sensibly beyond the outer limit or sensibly within the inner limit of the focal layer will contribute a still less fraction of its illuminating power to the spurious disc or star image.

On careful consideration it will be conceded, I think, that the thickness of the focal layer, when defined as that thickness necessary for the condition that a ray focussing upon one of the limiting planes shall produce a penumbra upon the *focal plane* of a diameter equal to twice that of the star disc, errs if anything on the side of liberality; for the integrated values of the very small fractions of the light contributed to the star disc from the colours (if any) focussing at various distances outside the limits of the focal layer can scarcely be supposed to balance the loss (rising upwards to 75 per cent.) of light incurred by the star disc as regards those colours which focus at points just *inside* the limits of the focal layer, and yet just outside the limits of sharp focus, or between the outer dotted and the inner solid lines in the diagrams. Hence the luminous value of the light of that range of wave length $\Delta\lambda$ which is embraced between the limits of the focal layer may be taken as a fair and very liberal measure of the light-grasping power of the objective when used for star work.

Although the observations recorded in Table VI. do not admit of great exactness, especially when $\frac{F}{A}$ becomes great, yet they seemed to me reliable enough to prove that the thickness of the visual focal layer does not vary as $\left(\frac{F}{A}\right)^2$, but varies roughly as $\left(\frac{F}{A}\right)^{1.6}$, since doubling the ratio $\frac{F}{A}$ was found to be about *treble* the thickness of the focal layer (or rather

* This fraction should really be considerably less than one-quarter, since it is a well-known fact that the greater portion of light in the out of focus penumbra is concentrated in the outer annulus.

more than that). Turning again to Fig. 1, it will be seen that I have indicated one focal layer $f_1 - - f_1$ just where the published measurements of the Lick refractor state it to be situated, its centre or the focal plane being at '27 inch *behind* the minimum focus. Now the curve L - - L - - L in Fig. 1 (as in Figs. 2, 3 and 4) is the curve of luminous intensity for the normal solar spectrum, the wave length scale being exactly the same as that at the left-hand end of each diagram. For this luminosity curve I am indebted to the very valuable researches and experiments of Captain Abney and Major-General Festing, as published in the Bakerian Lecture for 1886.*

Since Fraunhofer's first attempt to measure the relative luminous values of the various colours of the solar spectrum, several systematic photometric investigations with the same object have been entered upon, especially those of Vierordt in 1869; but I venture to think there are no photometric measurements of the relative luminous values of the coloured constituents of white light which can be more safely relied upon than those embodied in the luminosity curves L - L - L here presented. Captain Abney and Major-General Festing found their own eyes to be very fairly typical of the average results obtained by them when testing the colour-sensitive-ness of other persons experimented upon.

They also well established the law that the visual photometric value of any mixture of colours is always equal to the simple sum of the separate visual photometric values of the separate coloured constituents, *whether the constituents are complementary or not*, and this supplies additional reason for doubting the existence of the supposed visual focal layer $f_1 - - f_1$ (Fig. 1) in the case of the Lick refractor.

I should remark that Captain Abney's luminosity curve is the curve for the *prismatic* spectrum, and gives the maximum intensity about wave length '576 (citron yellow). On converting Captain Abney's curve into the curve for the *normal* spectrum with great care, I obtained the curve L - L - L with the maximum intensity transferred to wave length '565, citron green in colour. It will be noticed that the Lick refractor is very exactly corrected to refract this most luminous colour to minimum focus.

Now in Fig. 1 the outer limits of the focal layer $f_1 - - f_1$ (placed in accordance with Mr. James Keeler's estimate of the position of the visual focal plane) cut the colour curve at two points near C in the red, and at two points near F in the greenish blue. If four horizontal lines are drawn through these points right across the luminosity curve L - L - L, then we get the two approximately rectangular strips $l - - l$ and

* "Colour Photometry," *Phil. Trans.* Part ii., 1886.

$l_1 - l_1$, and obviously the amount of light embraced by the focal layer will bear the same ratio to the whole light passed by the objective as the ratio which the combined area of the two strips $l - l$ and $l_1 - l_1$ bears to the whole area of the luminosity curve $L - L - L$. Hence it can be seen at a glance that if the visual focal layer is really placed by the eye at $f_1 - f_1$, then the amount of light concentrated in the star image must be only about one-tenth part, at most, of the whole light transmitted by the objective! This is far too improbable to be true, and therefore, as well as for other reasons already partly stated, I feel very sceptical about the position of the visual focal plane of the Lick refractor being at $f_1 - f_1$, as it has been stated to be. Let it be supposed, on the other hand, that the focal layer is really situated at $f - f$, nearly tangential to the colour curve. Then, on drawing horizontal lines from the two points where the colour curve is intersected by the outer limit of the focal layer, across the luminosity curve, we get a strip which, besides being very much broader, also includes the very brightest part of the spectrum; and it can be seen from a glance at the diagram that the luminous value of the light concentrated into the star image will be at least one-half of the value of the whole light transmitted. Thus theory most certainly demands that the visual focal plane shall be so placed as to be nearly tangential to the bend of the colour curve.

It so happens that ordinary bright green glass, if of sufficient thickness, only transmits green light, whose maximum intensity is about wave length 5400, very close to the point of minimum focal length for ordinary objectives. Any observer possessing a large refractor of at least 8 inches aperture will find, as I have done, that if the focus is most carefully adjusted with a high power on a white star, and then the image is viewed through the green glass and a careful readjustment of focus made, that the eye places the focal plane for the unimpeded white light at about .02 inch only behind the green or minimum focus. I have also tried this method in the following case.

A 12.5-inch objective of 15 feet 5 inches focal length was arranged to be its own collimator; that is, it was placed close to, and with its optic axis perpendicular to, a plane optically-worked mirror. A small speculum metal bulb was placed in the eye end, just a little to one side of the principal focal point, which bulb produced an artificial star by reflecting the light from a very small electric lamp placed at one side. The light from this star diverged to the objective, passed out parallel, was reflected back by the mirror, and again converged by the objective towards a focus situated in the eye end close to the original star. This image, formed after two passages through the objective, could then be examined by